



INDEX

General Information.....	3
Downshift Lock-Out.....	7
Adjustment.....	9
Road Test.....	12
Valve Body removal and teardown.....	16
Governor and Rear pump removal and checks.....	24
Transmission Removal.....	33
Transmission Teardown.....	38
Component Assemblies.....	65
Transmission Systems General.....	94
Delayed shifting.....	98
Clutch Band Application.....	103
Test Data Guide.....	104

**Automatic Transmission Service Group
9200 South Dadeland Blvd.
Suite 720
Miami, FL 33156
(305) 670-4161**



INTRODUCTION

MERCEDES 722.5

*Updated
January, 2004*

Mercedes introduced the five speed automatic overdrive transmission in the 1989 model year. At a quick glance it looks the same as the four speed 722.3 and 722.4 models. The extension housing is the quickest way to identify the five speed unit, as this is where the overdrive section was added. The 4-5 and the 5-4 shifts are controlled by a computer module. This manual covers the testing, disassembly, inspection and reassembly of the Mercedes 722.5 unit.

*We wish to thank Mercedes Benz
for the information and illustrations
that have made this booklet possible.*

No part of any ATSG publication may be reproduced, stored in any retrieval system or transmitted in any form or by any means, including but not limited to electronic, mechanical, photocopying, recording or otherwise, without *written* permission of Automatic Transmission Service Group. This includes all text illustrations, tables and charts.

*The information and part numbers contained in this booklet have
been carefully compiled from industry sources known for their
reliability, but ATSG does not guarantee its accuracy.*

Copyright © ATSG 2003

DALE ENGLAND
FIELD SERVICE CONSULTANT

WAYNE COLONNA
TECHNICAL SUPERVISOR

PETER LUBAN
TECHNICAL CONSULTANT

JON GLATSTEIN
TECHNICAL CONSULTANT

ROLAND ALVAREZ
TECHNICAL CONSULTANT

GERALD CAMPBELL
TECHNICAL CONSULTANT

JIM DIAL
TECHNICAL CONSULTANT

ED KRUSE
TECHNICAL CONSULTANT

GREGORY LIPNICK
TECHNICAL CONSULTANT

DAVID CHALKER
TECHNICAL CONSULTANT

JERRY GOTT
TECHNICAL CONSULTANT

MIKE SOUZA
TECHNICAL CONSULTANT

AUTOMATIC TRANSMISSION SERVICE GROUP
18639 SW 107TH AVENUE
MIAMI, FLORIDA 33157
(305) 670-4161



722.5 5 Speed

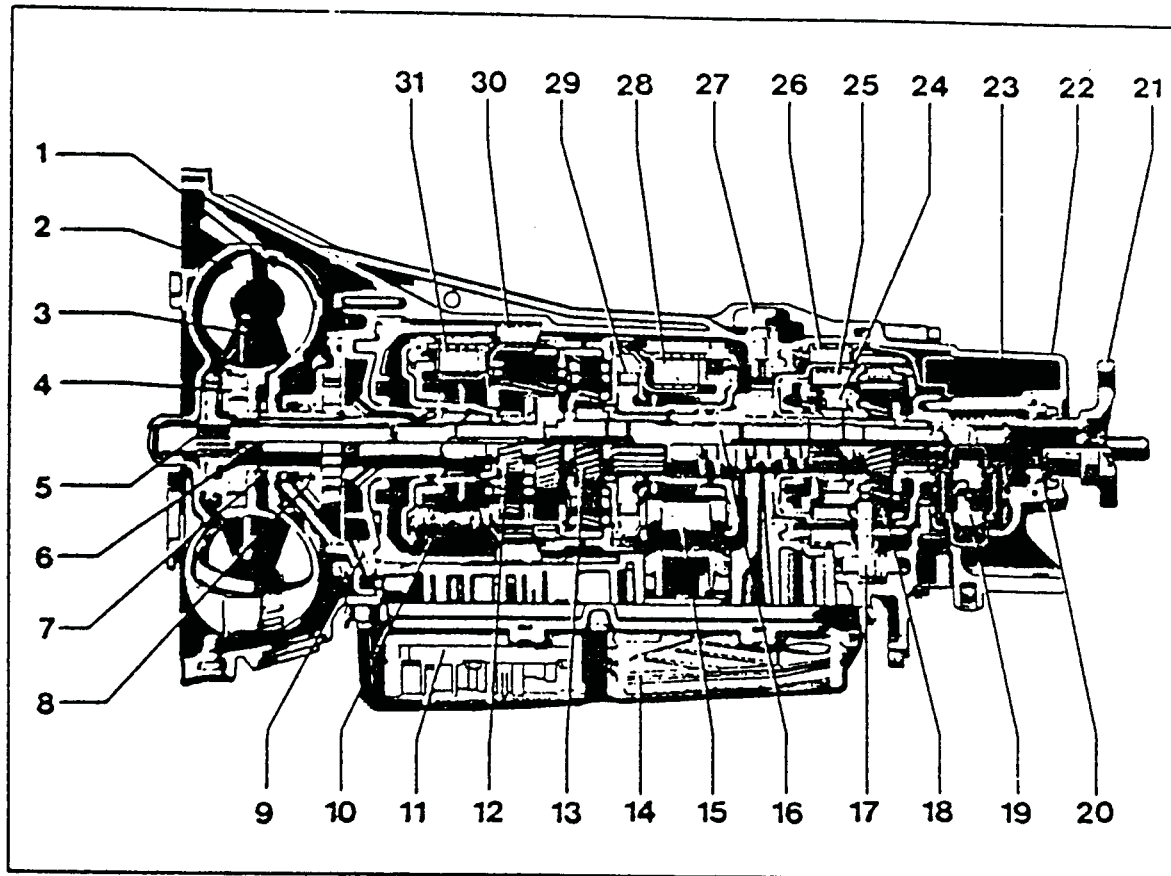

- | | |
|----------------------------------|----------------------------|
| 1-Primary Pump Cover | 17-Park Pawl |
| 2-Turbine Wheel | 18-Rear Planetary Gear Set |
| 3-Impeller | 19-Governor Assembly |
| 4-One way clutch | 20-Output shaft |
| 5-Input shaft | 21-Output Flange |
| 6-Stator shaft | 22-Extension Housing |
| 7-Primary Pump Cover Hub | 23-Oil Chamber. |
| 8-Primary Pump | 24-One way clutch F2 |
| 9-Pump Cover | 25-Clutch KS |
| 10-Brake Band 1 | 26-Brake BS |
| 11-Valve Body Housing | 27-Vent |
| 12-Ravigneaux Planetary gear set | 28-Clutch K2 |
| 13-Center Planetary gear set | 29 -One way Clutch F1 |
| 14-Oil Filter | 30-Brake B3 |
| 15-Brake band B2 | 31-Clutch K1 |
| 16-Intermediate shaft | |

AUTOMATIC TRANSMISSION SERVICE GROUP



Technical Service Information

Selector Lever Position

“D”

All five forward gears available normal operating conditions in all driving situations.

“4”

Transmission only will shift to fourth gear for high performance driving. Other selector positions are the same.

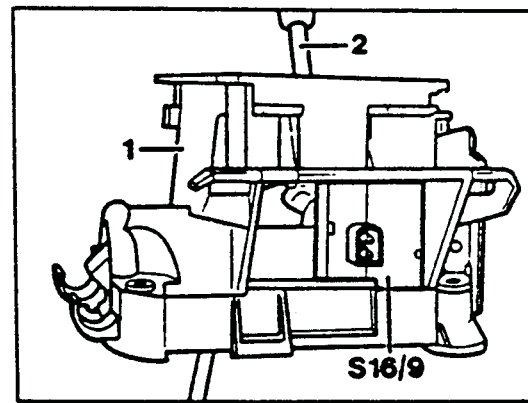
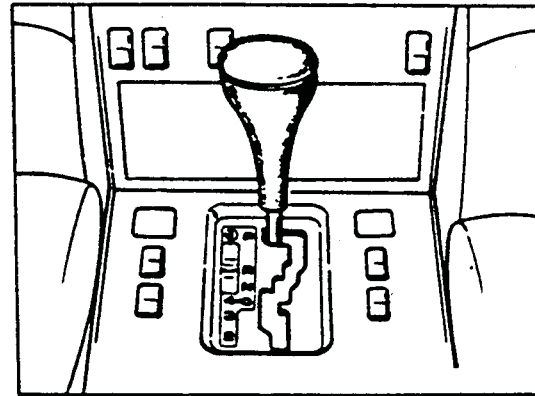

In “D” position power is switched on to control the (N15/1) computer module and the transmission can shift into fifth gear. When the transmission is shifted to fourth gear the (S16/9) is activated so as to cancel fifth gear. The activator switch is located in front of the shift gate.

Shifting conditions

Upshift 4-5

The upshifts to fifth gear depends on the following:

- Selector lever position “D”
- Intake manifold vacuum.
- Engine RPM

Depending on the intake manifold vacuum a certain speed must be reached to shift into fifth gear.

Downshift 5-4

There is a difference between shifting down (kickdown or coast down) or with the transmission selector lever.

The 5-4 Downshifts dependent on the following:

Selector Lever Downshift:

- Move selector lever from “D” to “4”.
- Engine Speed (RPM)

The transmission can be down shifted with the transmission selector lever (engine braking) or to increase pulling power by moving the selector from “D” to “4” unless engine speed was too high that the engine can be cut off by the governor.

Automatic Downshift (Kick-Down)

- Program Selector Switch.
- Engine Speed (RPM)
- Accelerator pedal position.
- Kick-Down Switch.

Depending on speed and selected range a certain accelerator pedal position must be exceeded or the kick down switch actuated to kick-down to fourth gear.



Technical Service Information

Throttle Valve Switch (TPS) (S29/4)

The accelerator position is measured by the TPS which determines downshift point.

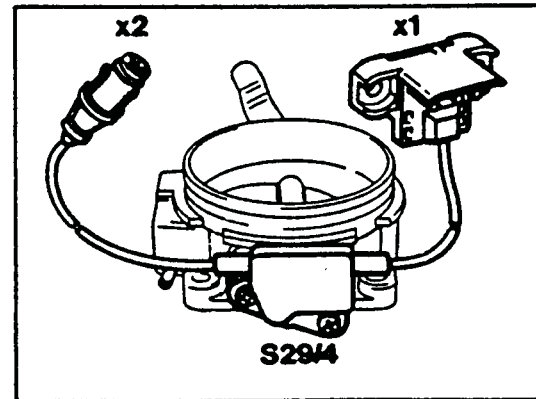

Regulation Valve (Y3/1y2)

The regulation valve is operated above 3rd gear with pulse driven voltage. Beginning with 4th gear it is supplied with oil under pressure thru release via B2. It regulates the pressure to the valve determined by the computer control in the transmission

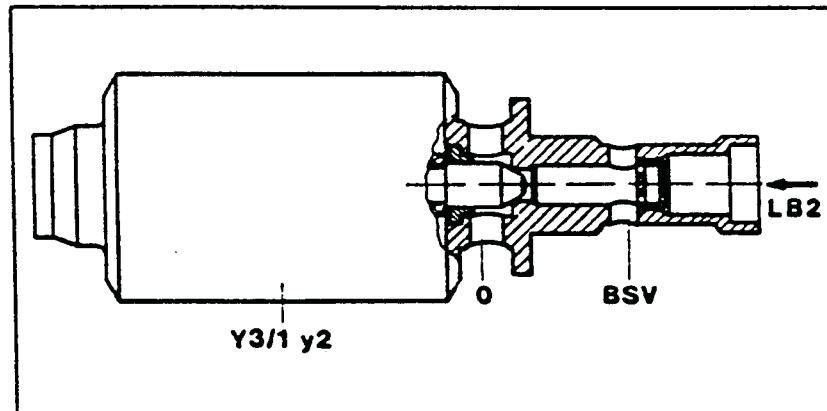

- 0 Zero flow
- LB2 Pressurized oil from release side of B2 Band
- BSV Valve pressure shift valve BS

Valve curve

The current for setting the valve pressure (P5) for the 5th gear is low and current for setting the valve pressure (P4) for 4th gear is high.

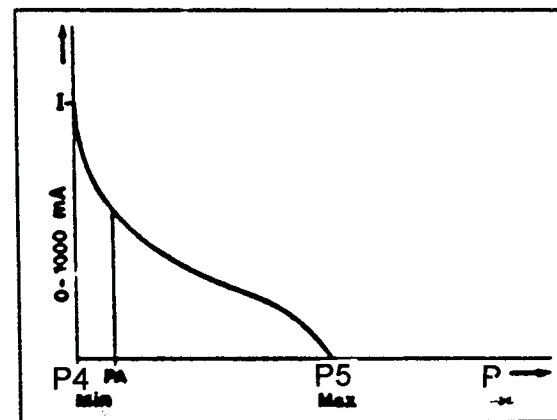



Control unit (N 15/1)

This hybrid transmission control unit is marked with the letters HGS. It is equipped with an installation aid and located at different positions depending on the model vehicle.

.Model 129 left hand steering

In units compartment fight front.

.Model 129 right hand steering

In units compartment left front.

.Model 124.051 Left hand steering

In units compartment right front.

.Model 124.051 left hand steering with ASR and cruise control

on cruise control mount below steering column.

Model 124.051 right hand steering on A-pillar at bottom left.

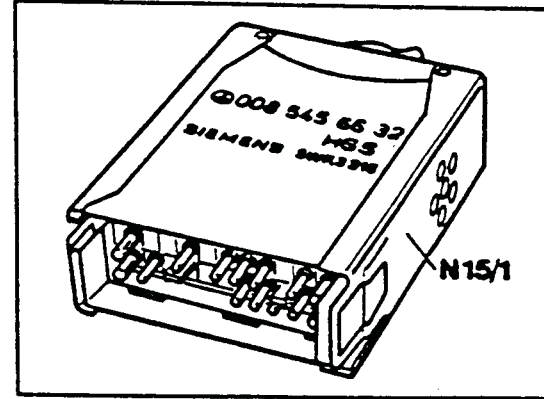

The control unit is connected to the cable harness with a 22 pole plug connector.

The control unit consists of a circuit board with electronic components and the housing. It serves to process and evaluate input signals and controlling the regulator valve according to the increase and reduction of current, that actuates the 4-5-4 shifts.

The regulation valve varies pressure in the lower cover, which acts on the shifting units BS and KS causing the transmission to shift to 4th or 5th gear.



Technical Service Information

FUNCTION OF DOWNSHIFT LOCK-OUT.

A downshift lock out is installed on the transmission side to protect the engine and transmission from improper operation.

Downshift lock-out "4"-3" or "3"-2"
Hydraulically controlled.

A downshift with the selector lever from "4"-3" or "3"-2" is prevented in the upper speed range (kickdown shift limit exceeded) by the downshift lock-out. The downshift lock-out is controlled hydraulically by the pressure regulator and the mechanical lock-out by a locking lever which pivots below the catch plate.

In addition to its previous function of preventing the shift "N"-R" the lock-out piston (65) for reverse gear now has two additional functions. This means that the lock-out piston now extends in three stages instead of one stage as previously. A two stage locking lever(152) connected to the lock-out piston (22) via a linkage (150) pivots below the catch plate (82) preventing manual downshift with the selector lever.

It is possible to shift down manually only after the speed has dropped to below a certain value and the lock-out piston moves the locking lever back out of the lock-out position.

- 65 Lock-out piston/reverse gear
- 72 Leaf Spring
- 82 Catch Plate
- 150 connecting rod
- 151 Adjustment/retaining screw
- 152 Locking lever
- 153 Retaining Bolt
- 154 Plastic Sleeve
- C Lower Cover

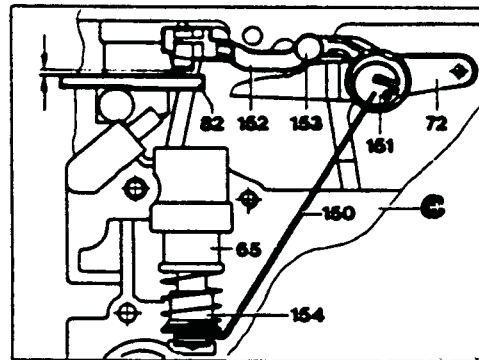

DOWNSHIFT LOCK-OUT FOR SELECTOR LEVER.

Model	Above km/h (approx. values) it should not be possible to shift down with the selection lever	
	4 → 3	3 → 2
124.051	143-124	98-82
129.051	147-128	101-85

5-4 Downshift Lock-out (electronically controlled)

Above a certain speed the 5th gear also remains engaged, even when the selection lever is moved from position "D" to "4" for deceleration. This is controlled by the control unit (N15/1).

NOTE;

THERE ARE TWO VERSION CONTROL UNITS. ONE FOR A MECHANICAL SPEEDOMETER AND ONE FOR A DIGITAL SPEEDOMETER. DO NOT MIX-UP, BECAUSE THE 5-4 DOWN SHIFT LOCK-OUT WILL NOT FUNCTION.



Technical Service Information

KICK-DOWN SHUT OFF

IN ORDER TO GET THE ENGINE UP TO MAXIMUM SPEED WITH THE KICK DOWN SWITCH, THE KICK DOWN FUNCTION IS HYDRAULICALLY COUPLED WITH THE MAXIMUM ENGINE RPM. Just before reaching the maximum RPM the kick-down current is interrupted electronically (fuel pump relay or control unit compressor shut-off). This assures that the transmission shifts to the next higher gear just before reaching the maximum engine RPM.

TRANSMISSION SHIFT POINT INCREASE 2-3 ON VEHICLES WITH CATALYTIC CONVERTER

The idle shift point for the 2-3 shift is increased for a short time so that the catalytic converter reaches its operating temperature more quickly during the warm-up phase. The idle 2-3 upshift is then accomplished at a speed of 40-55 km/h depending on the rear axle ratio.

FUNCTION

Switch over valve (Y3/2) receives power from control unit CIS-E (N3) and the relay for the transmission shift point increase (K29). The governor pressure is decreased by a pressurized oil line connected to governor pressure test connection and the adapter and by an additional oil line (0) inserted into a hole on the transmission housing. When certain conditions are met (coolant temperature, speed and time) the power to the solenoid valve is switched off and the governor pressure builds up to full value.

Increase Conditions

The transmission shift point increase for the 2-3 upshift is effective only at cooling water temperatures of 0-60' C. The switch on duration depends on the

cooling water temperature when the engine is started. It is longest at temperatures between 20-30'C. amounting to 60-80 seconds in this case.

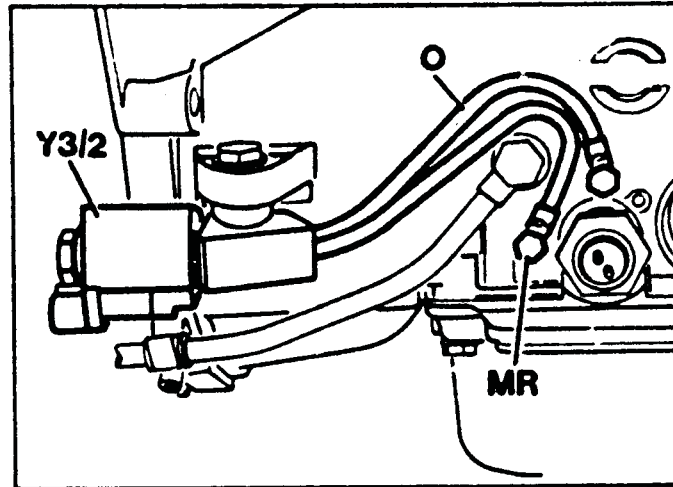

0 Drain oil chamber

MR Test connection, governor pressure

Y3/2 Switch over valve, shift point increase.

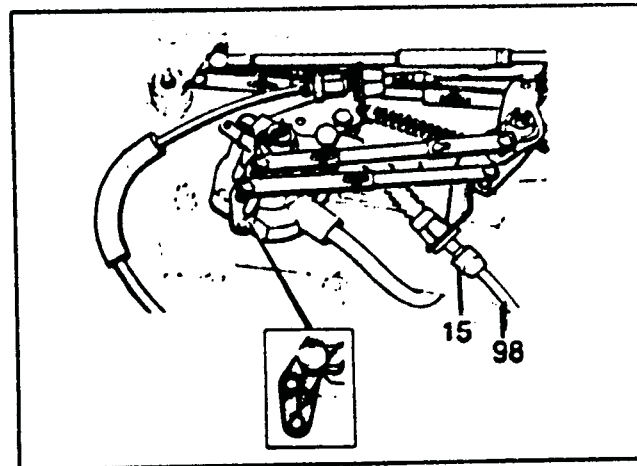

ADJUSTMENT

ENGINE CONTROL MUST BE ADJUSTED CORRECTLY

1-Remove air cleaner

2-Control pressure cable connected. Adjust control pressure cable (95) by turning adjustment screw (15) so that the tips of the pointers coincide.



Technical Service Information

REMOVAL, INSTALLATION AND ADJUSTMENT OF CONTROL PRESSURE CABLE WITH VACUUM ELEMENT, VEHICLES WITH PROGRAM SELECTOR SWITCH.

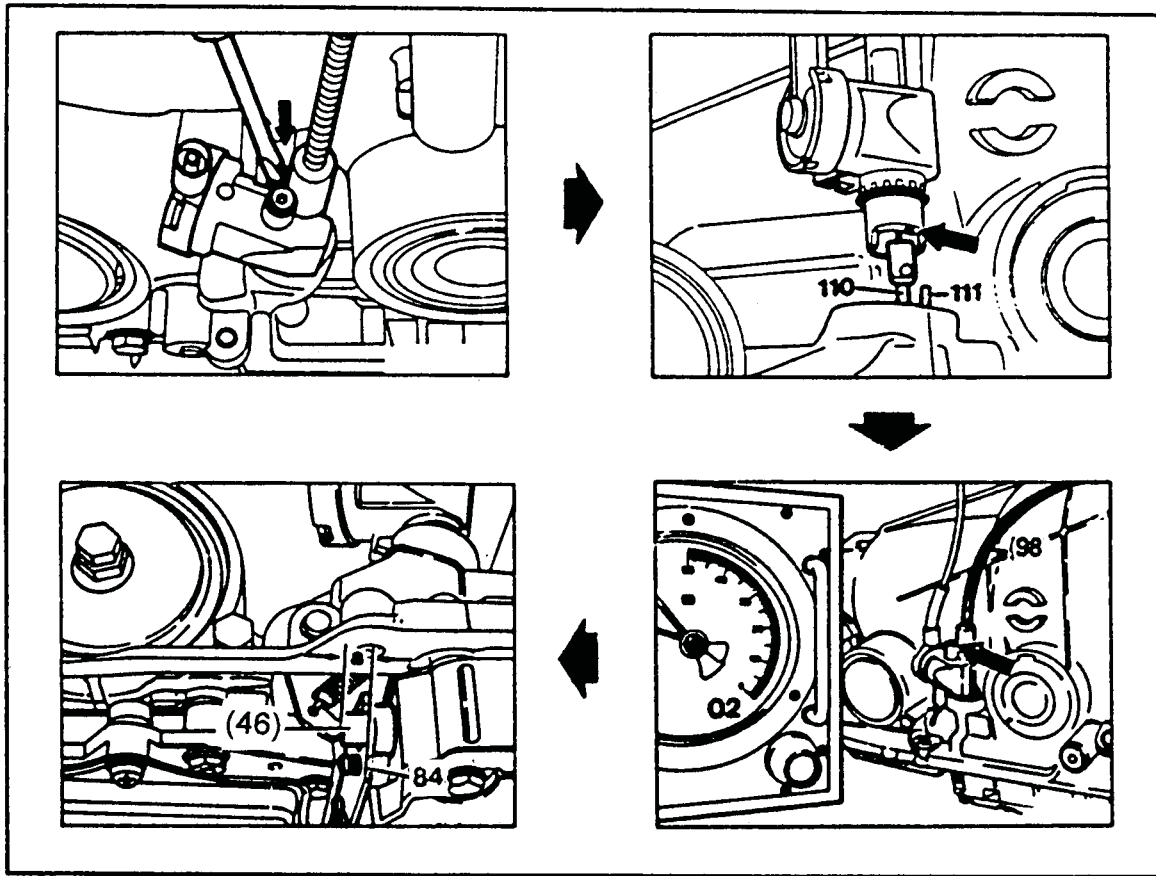

TESTING PROGRAM SELECTION SWITCH

Test step Scope of test	Test connection: Tester	Actuation Prerequisite	Nominal value	Possible cause/ remedy
Check vacuum on vacuum element, control pressure cable	Connect vacuum tester to vacuum unit, control pressure cable with Y adapter	Engine at idle, program selection switch position "E"	approx. 400 mbars	Switch-over valve (Y4) switch selection program (S15) Vacuum line
		Position "S"	0 bar	

REMOVAL, INSTALLATION

Control pressure cable (98)

disconnect lock on transmission with a screw driver (arrow) and unhook connecting rod (110), connect. To install remove transmission oil pan, insert limitation rod (111) into hole (arrow) and install control pressure cable. Turn control pressure cable until lock catches.

ADJUSTMENT

Tester (vacuum Gauge
CONTROL PRESSURE CABLE(98)

connect to vacuum tap and activate with vacuum.

pull back against full load stop. Measure dimension "a" from front of control pressure valve (46) to connecting plate (84). Adjust dimension "a" to 7mm with allen screw (arrow).



Technical Service Information

ADJUSTMENT OF MANUAL CONTROL ROD

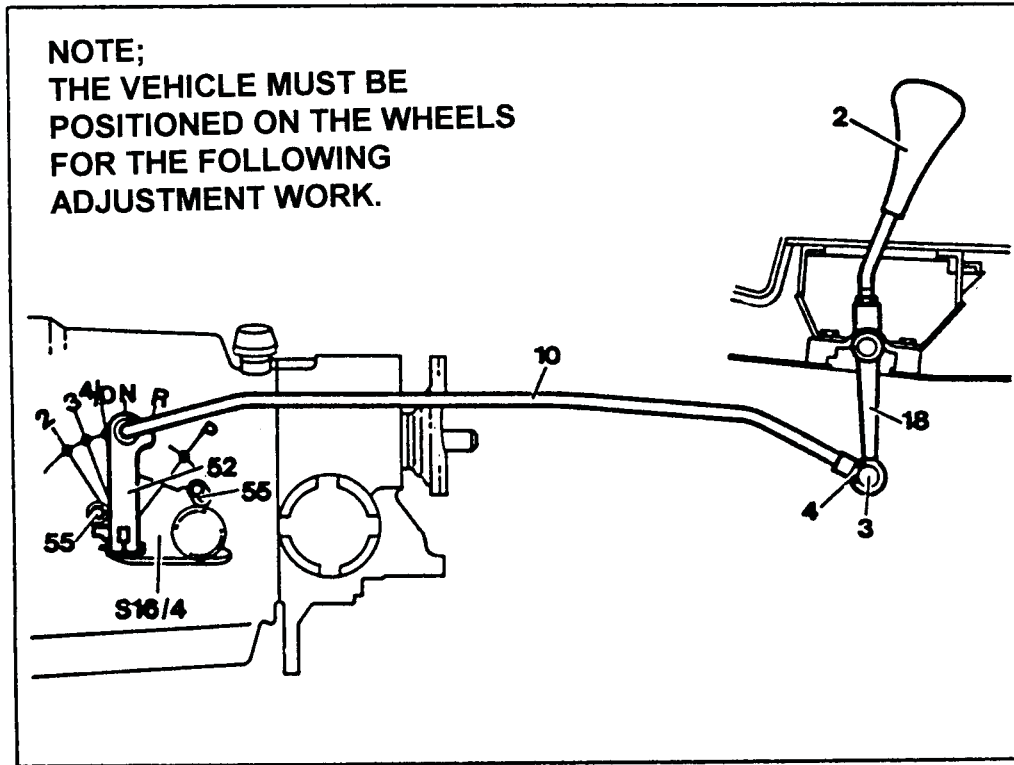

Control rod (10).....

Range selector lever (52).....

Counter nut (4).....

Control rod (10).....

Plug, starter lock-out switch (8)....

Control rod (9).....

Range selector lever (52).....

Starter lock-out switch (53).....

**DISCONNECT AT SELECTOR
LEVER SHAFT (18).
Shift to "N" position.**

Loosen and adjust length of control rod (10) so that play of approx. 1mm is present between the selector lever (18) and the "N" stop in the shift gate.

Connect and secure, tighten counter nut.

Turn lock-up and carefully press off with two screw drivers.

Remove after removing retainer clip.

Remove after taking off hex bolt (51). When installing assure that driver (54) engages in range selector lever.

To remove unscrew hex bolt (55). To install insert 4mm dia. punch through driver (54) and locating hole in shift housing and locate starter lock-out switch.



REMOVAL, INSTALLATION

1 Release lock for plug, starter lick-out switch(8) by turning white plastic ring (arrow) upward in direction of arrow.

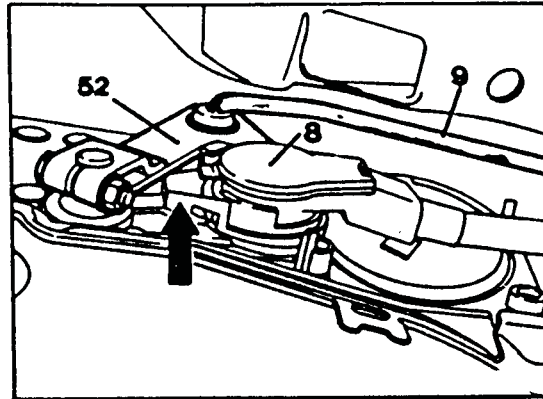

2 Carefully pry off plug with two screw drivers under the tab and the cable exit,

3 Disconnect control rod.

4 Screw off hex head bolt (51) and pull off range selector lever (52).

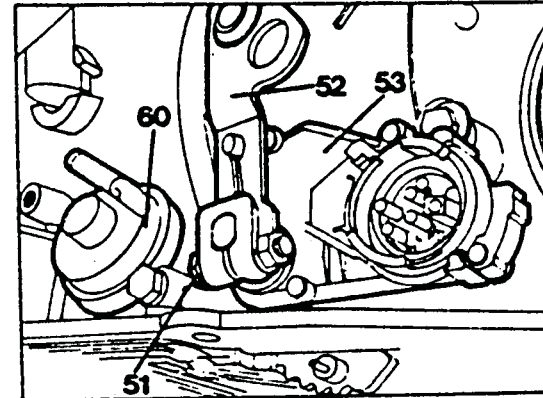

INSTALLATION NOTE;
Attach range selection lever so that driver (54) engages in lever.

5 Screw out both bolts (55) and remove starter lock-out switch (53).

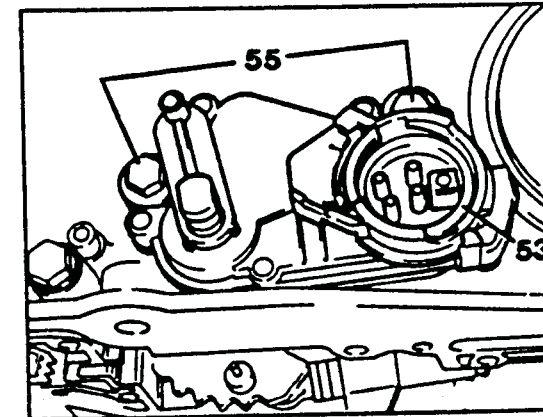

INSTALLATION NOTE;
Shift range selector lever position "N". Insert 4 mm dia. pin or drill in switch housing, then tighten retaining bolt (55). Remove locating pin (arrow).

6 Install in reverse order.

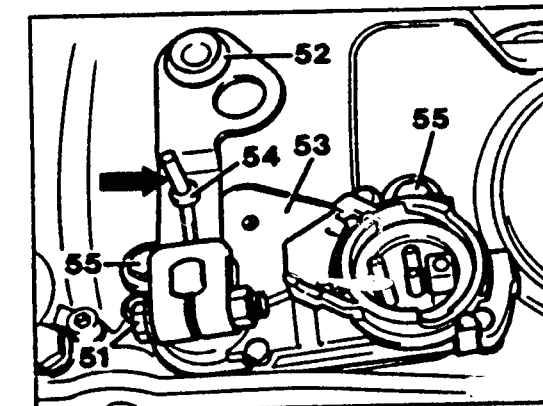



CHECK-UP DURING TEST DRIVE

NOTE;

The test methods described are used to check the normal functions of the automatic transmission. Evaluation of the function and any possible malfunctions of the transmission naturally requires experience with automatic transmissions.

Before starting the test, check the oil level in the transmission, the engine idle speed and adjustment of the TV pressure cable (control cable).

During the test try not to exceed continuing shift cycles every 15 seconds. This can cause the unit to over-heat. Heat builds up on the servo elements in the unit.

TEST DRIVE

During the test drive check whether the transmission shifts in all 5 gear ranges.

- A. Shift vehicle to highest gear.
 1. Shift selector lever to position "4"
 2. Accelerate to 90 km/h
 3. Release accelerator pedal to idle position.
 4. Then immediately shift selector lever from position "4" to "D"
 5. The transmission should shift from 4 to 5
 6. Move the selector lever from "D" - "4" = transmission should shift 5-4
 7. Move selector lever from "4" - "3" = transmission should shift from 4 - 3
 8. If transmission down shifts twice = all gears are present.
 9. If transmission does not down shift when selector lever is moved from "D" - "4" = one gear is missing.

B. MEASURE SPEED RATIO

10. Speed = 100 km/h

11. Check engine RPM in selector lever positions "3", "4", and "D"

3rd gear = approx. 4500 RPM

4th gear = approx. 3150 RPM

5th gear = approx. 2300 RPM

Check missing gear by comparing engine speed.

C. In addition to checking shift points check shift feel.

Upshifts at part throttle should be just noticeable. At full throttle or kickdown shift should be clearly noticeable. A revving engine on shifts will indicate that either a band or clutch pack is slipping.

Coast downshifts at very low speed should be noticeable by changes in engine RPM. In certain speed ranges part throttle down shifts can occur.

Downshifts with the selector lever are either downshifts with throttle depressed (e.g. uphill) or deceleration downshifts with the throttle released (e.g. downhill or deceleration). Down shifts with throttle released



Technical Service Information

SHIFT POINTS IN SELECTOR LEVER POSITION "D"

NOTE
 All speeds indicated are approximate values. they apply for the standard rear axle ratio and tires. Deviations from the specified values can result due to transmission production tolerances as well as speedometer tolerances.

NOTE SHIFT POINTS IN SELECTOR LEVER POSITION "2" AND "3"

The 1-2 upshift in the selector lever position "2" is accomplished only at the maximum engine RPM with the throttle fully depressed. Shift points in selector position "2" and "3" are not specified for simplification.

Vehicle selection program: Switch position
 E=economy
 S= standard

Shift points in selector lever position "D"1)

Model	Acceleration pedal position	Shift at km/h (approximate values)															
		1 → 2		2 → 3		3 → 4		4 → 5		5 → 4		4 → 3		3 → 2		2 → 1	
		E	S	E	S	E	S	E	S	E	S	E	S	E	S	E	S
124.051	Full throttle	-	34.5	48	84	101	135	211	211	150	180	39	84	21.5	40	-	16
	Kick-down		53		92		144.5		211		200		132		81.5		33
129.061	Full throttle	-	36	50	87	104	140	217	217	155	186	41	87	22	42	-	16
	Kick-down		55		95		150		217		206		137		84		34

1) - For national versions the values for the standard version in switch position "S" apply.

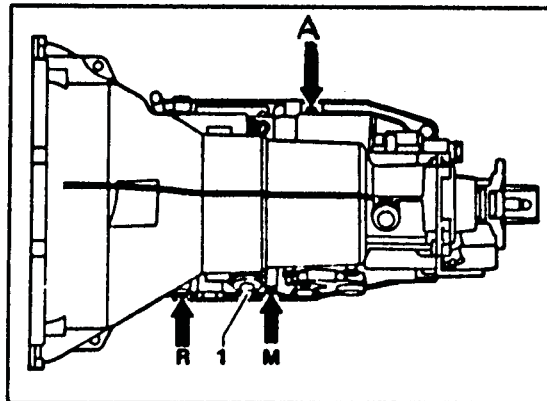

Vacuum control unit (1)..... for measuring modulating and operating pressure connect vacuum line to vacuum control unit (item 1),
 Test operating pressure (A). connect pressure gauge with scale range to 25 bars.
 Test modulator pressure(M) connect pressure gauge with scale range to 10 bars.
 Test governor pressure (R).. use same gauge for modulator pressure ,



NOTE

To measure the operating pressure, modulating pressure and governor pressure, position the pressure hoses through right front door window and roll up the window to hold in place. The pressure hoses should not sag or touch the exhaust pipe

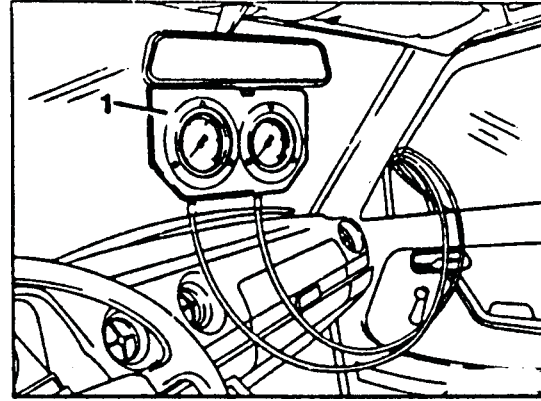

Measuring modulator pressure

1 Disconnect vacuum line (10) on vacuum control unit (60).

2 Operate vehicle approx. 50 km/h with the selector lever in position "D" and read off pressure value.

Adjustment of modulator pressure

3 Remove rubber cap on vacuum control unit.

4 Pull retaining plate (2) out of retaining slots until it can be turned.

5 The adjustment screw in the vacuum control unit can then be adjusted with the retaining plate. One rotation of the adjustment screw changes the pressure approx. 0.4 bars.

6 After adjusting the adjustment screw, press the retaining plate back into the retaining slots.

7 Reinstall rubber cap on vacuum control unit (60)

8 Measure modulating pressure again

9 Reattach vacuum line (10)

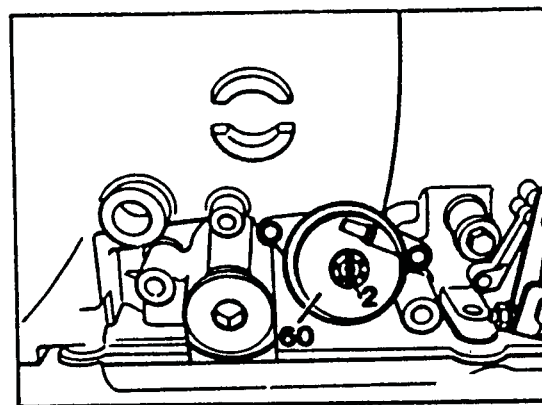
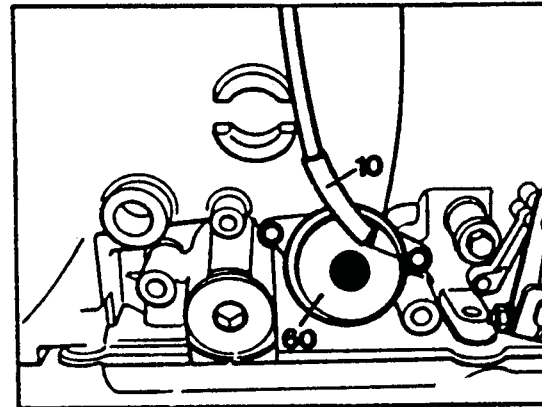



MEASURING OPERATING PRESSURE

10 Disconnect vacuum line on vacuum control unit

11 Start engine and allow to run at approx 1000 rpm and read off pressure value with selector lever in "D".

Note operating pressure cannot be adjusted,

MEASURING GOVERNOR PRESSURE

Operate vehicle on road test at speeds⁰ specified in tables and read off pressure values. If no governor pressure is indicated on gauge, remove governor and clean.

If all the pressure values deviate from the values specified in the tables, replace the governor.

NOTE FOR VEHICLES WITH CATALYTIC CONVERTER.

On vehicles with shift point increase feature unscrew the pressure oil line on the test connection for the governor pressure.

INSTALLATION NOTE

First tighten pressure oil line (MR), then oil line (0) and holder for switch-over valve (Y3/2).

- 0 Return line oil sump
- MR Test connection, Governor Press.
- Y3/2 Switch-over valve shift pt. increase

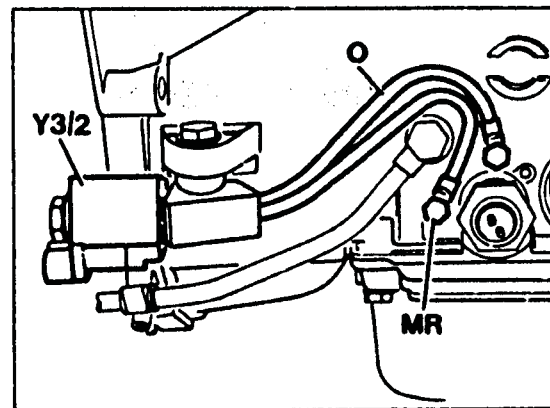



REMOVAL, INSTALLATION

1 Screw out drain plug (4a) and drain fluid.

2 Screw out mounting screws (4) and remove oil pan (3)

INSTALLATION NOTE;

Tightening Torque drain plug 14 Nm
Pan bolts 8Nm.

3 Screw out phillips screws (6) and remove oil filter.

4 Move selector lever to "D" position.

5 Screw out mounting screws (7) and (7a) and remove shift valve housing (A).

INSTALLATION NOTE

Tightening Torque 8 Nm

Assure that the range selection valve (A1) engages in the driver (arrow).

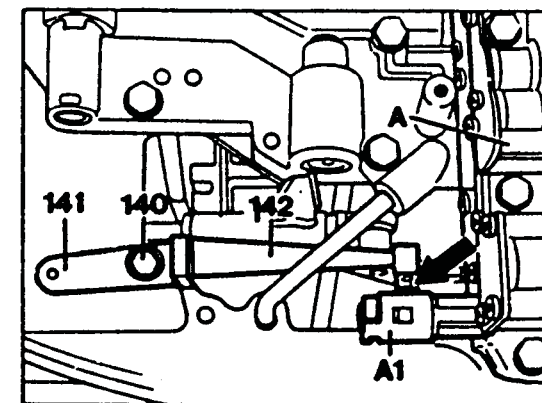
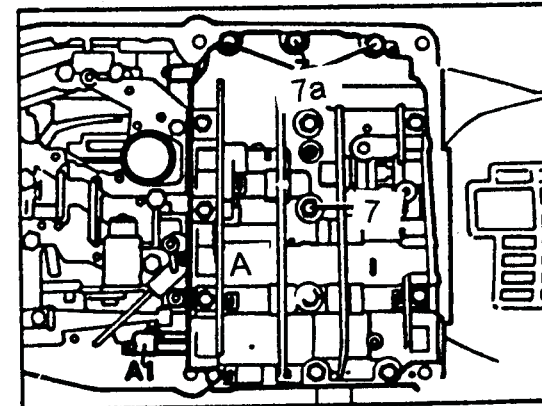
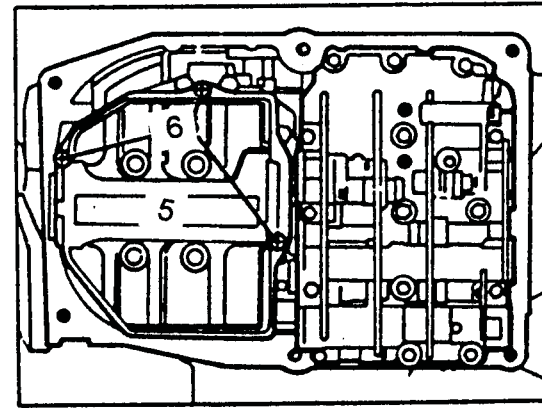
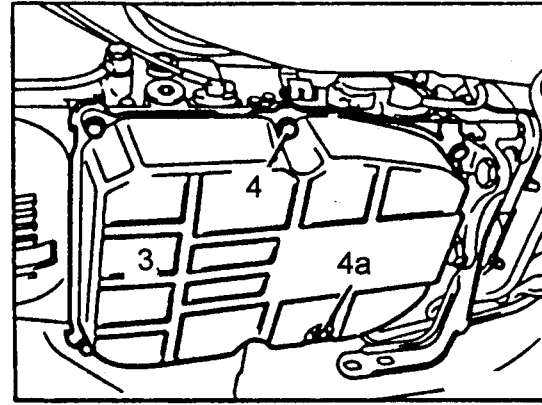



VALVE BODY TEARDOWN AND ASSEMBLY

Observe cleanliness when working with the valve body. Do not use fuzzy rags because this can cause hanging of valve and cross leaks. remove screws indicated by arrows, remove valves (13,24,86) and retainer (33a).

INSTALLATION NOTE;
Tighten screws lightly so that housings are able to move so as to install all the screws. Insert valves (13,24,86) and retainer (33a) in housing.

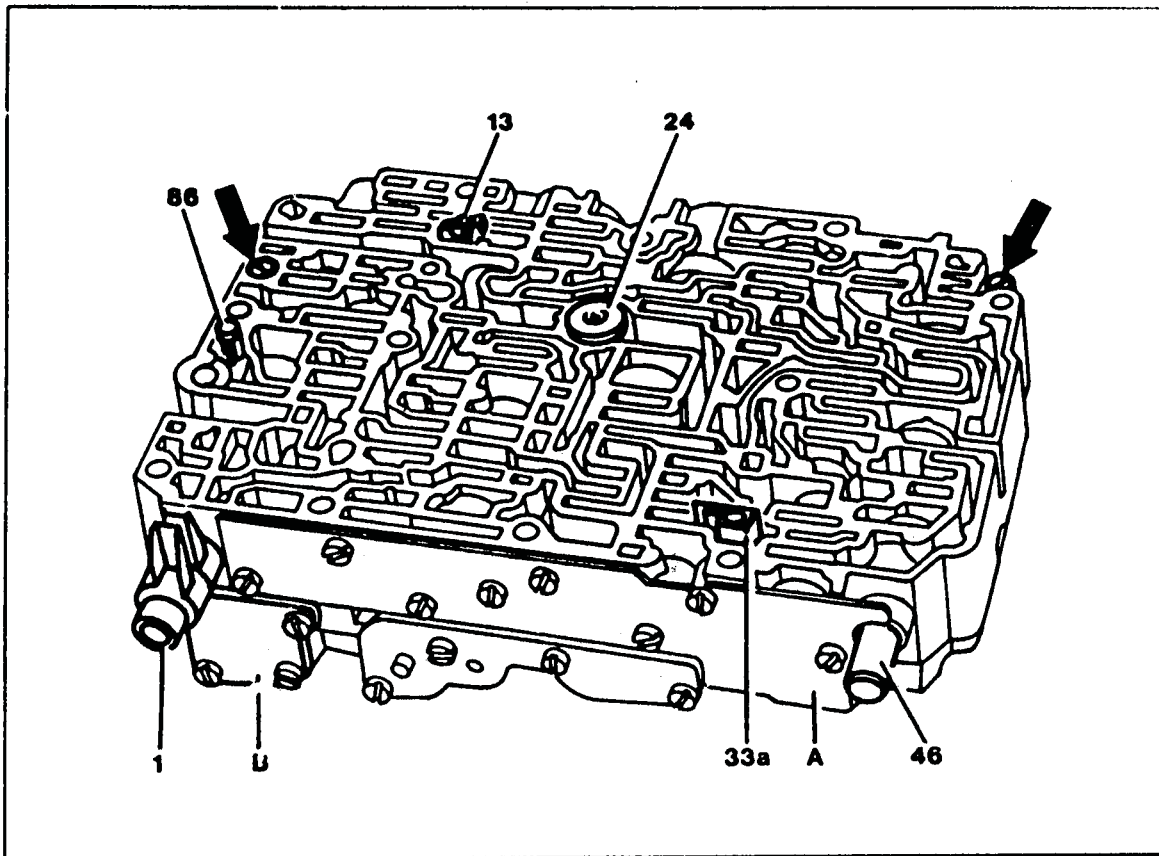

- | | | | |
|----|-----------------------------|-----|---------------------------|
| 13 | Plate check valve with bore | 33a | clamped retainer B2 valve |
| 24 | Check valve-primary pump | 86 | Drain Valve LB3 |



Technical Service Information

Carefully lift damper housing (B) together with separator plate (4).

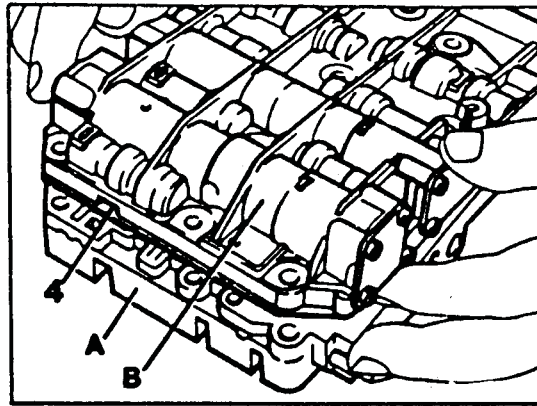

Remove all 19 check balls (14), The valve ball marked with 14 is positioned on a conical spring.

Remove valves, filter and shift pin.

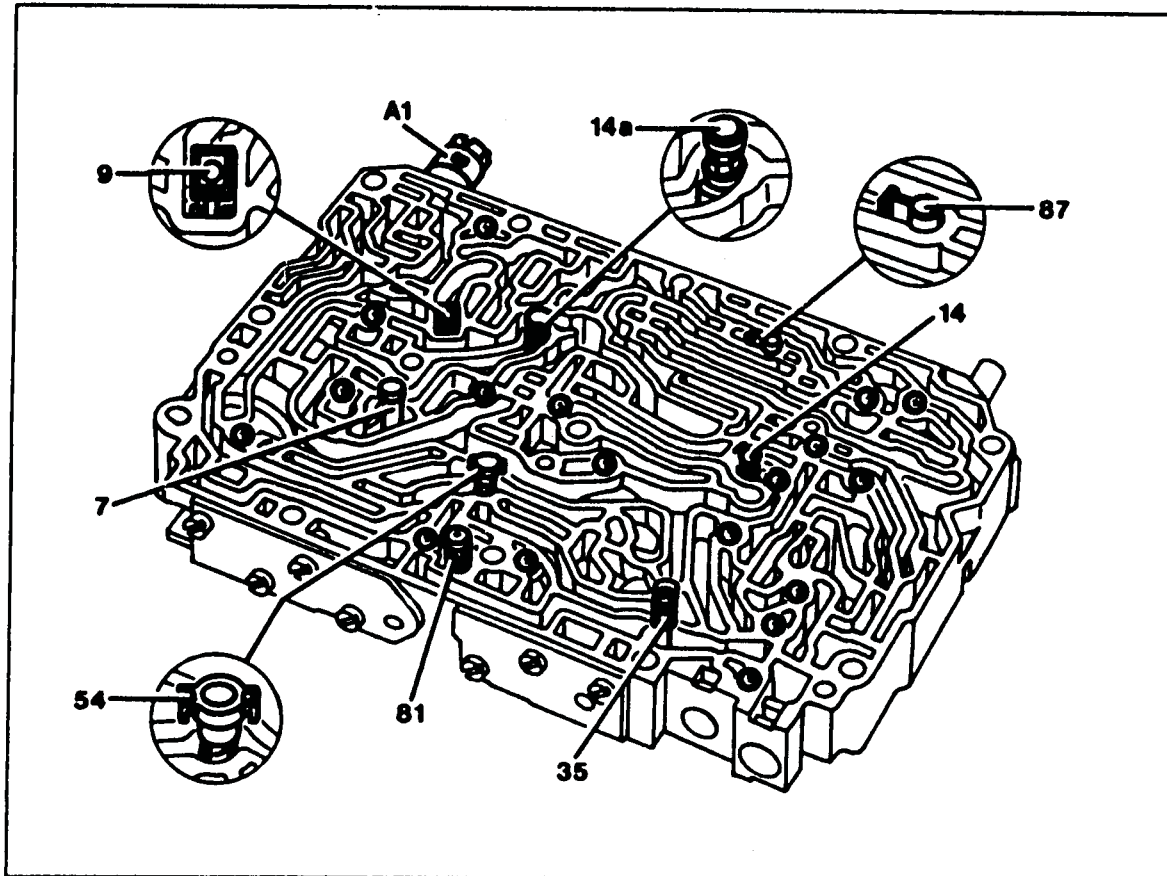

- A1 Manual Valve
- 7 Shift valve K1
- 9 Check valve (white)
- 14 check balls (19)
- 14a Pressure valve

- 35 Shift pin lube pressure
- 54 Check valve
- 81 Sieve filter
- 87 Throttle Valve



Technical Service Information

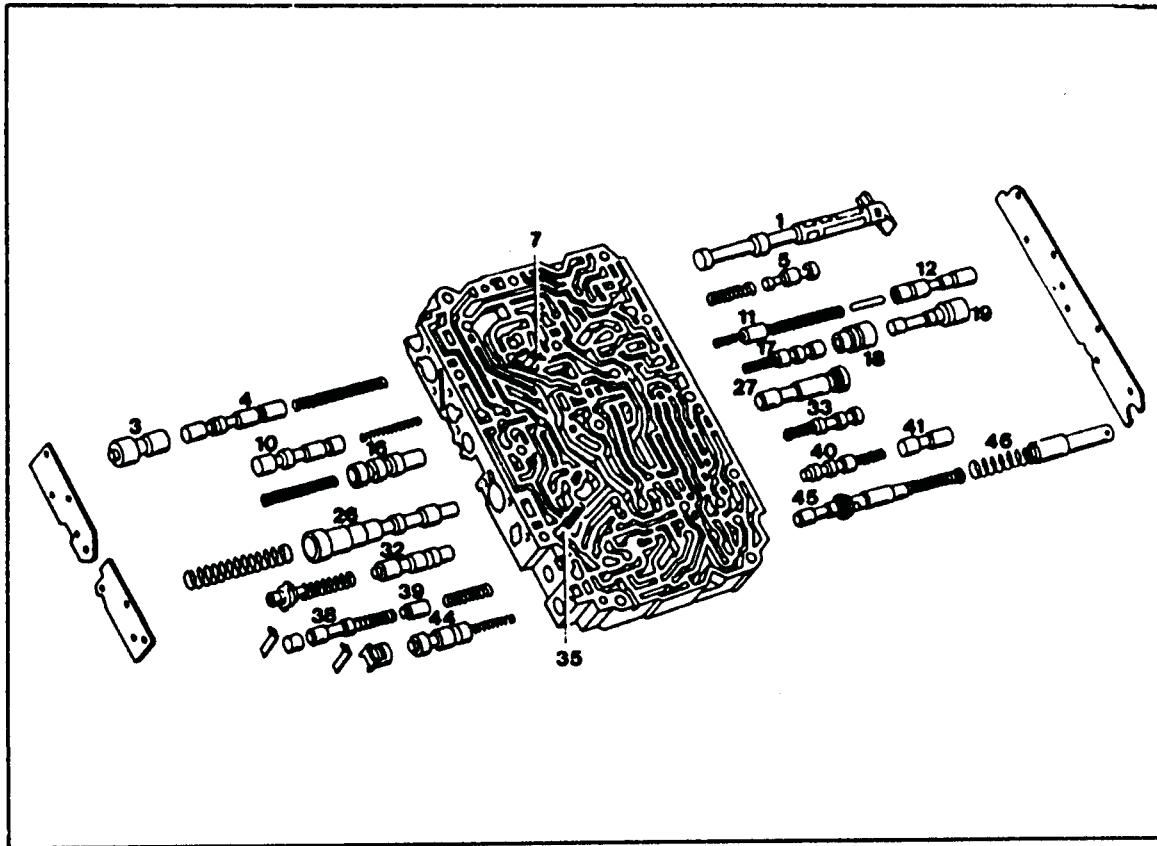

- | | |
|----------------------------------|--|
| 1 Manual Valve | 26 Regulator valve oper. press. |
| 3 Piston control valve 2-3 | 27 Plug, Shift valve Ku |
| 4 Control valve 2-3 | 32 Regulator valve, Full TV |
| 5 Regulator valve Torque Conv. | 33 Shift valve B2 |
| 7 Lock-out valve K1 | 35 Shift pin lube press. |
| 10 Shift valve B1 | 38 Regulator valve B1 |
| 11 Piston control valve 3-4 | 40 Shift valve, kick down |
| 12 Control Valve 3-4 | 41 Shift valve Gov. Press. |
| 16 Regulation valve basic press. | 44 Amplification Valve Gov. |
| 17 Control Valve 1-2 | 45 Regulator valve, cont.l pressure |
| 18 Sleeve control valve 1-2 | 46 Piston, regulator valve control pressure. |
| 19 Piston control valve 1-2 | |



Technical Service Information

The arrow indicates the position of the allen screw for full throttle control pressure. Turning clockwise results in earlier full load or kick-down upshifts. Turning counter-clockwise results in later upshifts.

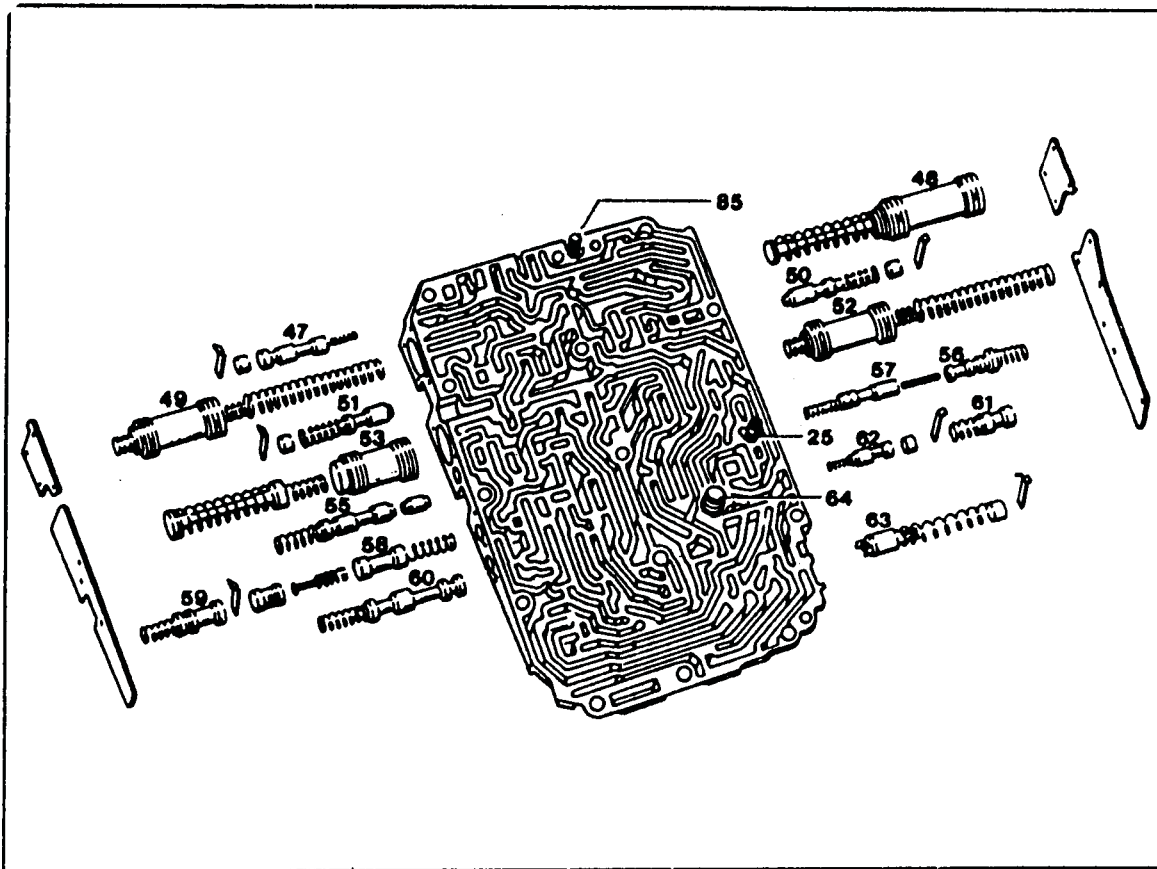
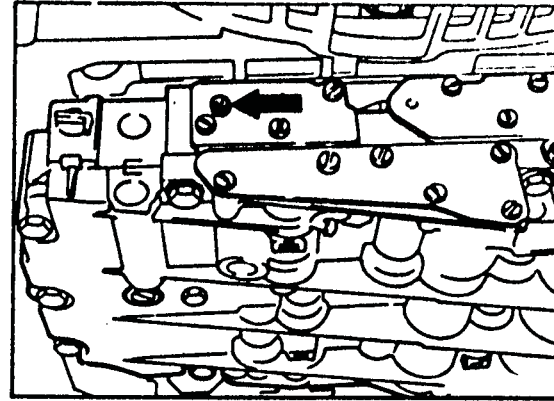

- | | |
|-----------------------------------|--------------------------------------|
| 25 Relief valve (modulator press) | 57 Regulator valve damper B1 |
| 47 Regulator valve shift pattern | 58 Regulator valve damper, switch on |
| 48 Damper K1 | 59 Shift valve K2 |
| 49 Damper K2 | 60 Release valve B2 |
| 50 Regulator valve damper K1 | 61 Lock-out valve deceleration |
| 51 Regulator valve damper K2 | 62 Lock-out valve RV1 |
| 52 Damper B1 | 63 Damper, kick-down |
| 53 Damper switch on | 64 Lubrication pressure valve |
| 55 Lock-out valve RB2 | 85 Pressure limitation valve. |
| 56 Shift valve deceleration | |

AUTOMATIC TRANSMISSION SERVICE GROUP



Technical Service Information

VALVE BODY CONTINUED

1-Turn adjustment and retaining plate (151) to right with screw driver and disconnect linkage.

2-Pivot locking lever (152) below catch plate (82)

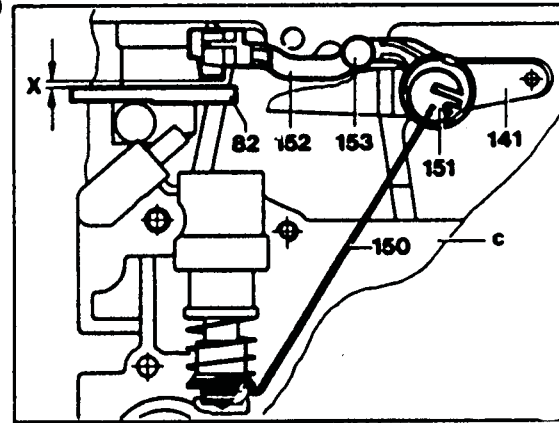

INSTALLATION NOTE;

Adjust play "XX" = 0-0.5mm of locking lever (152) with adjustment and retaining plate.

3-Screw out clamping screws (139)

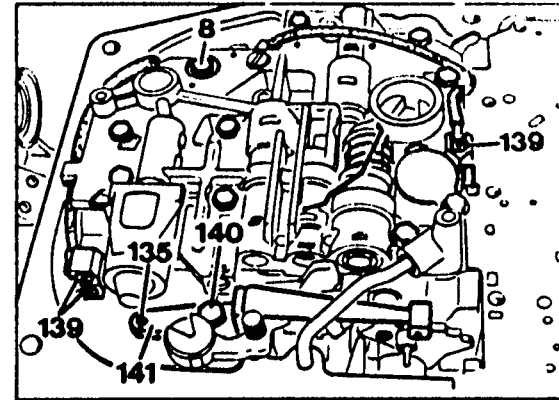

4-Screw out hex head bolt (140) remove retainer (141) with catch spring (142) and locating pin (135), Screw out hex head bolts (8)

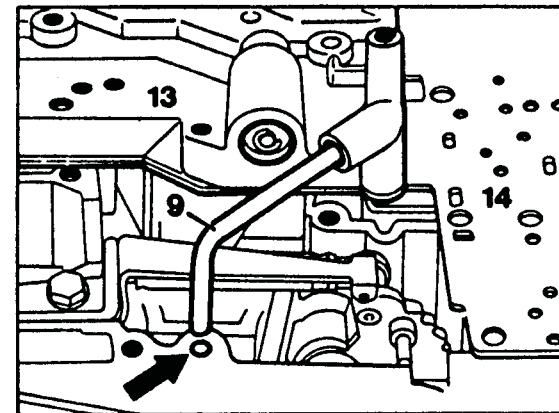

5-Remove lower cover (13) together with intermediate plate (14) and oil tube (9).

INSTALLATION NOTE;

Insert oil tube (9) into hole arrow.

Insert hex head bolts (8), do not tighten. Screw in two bolts (7) to locate separator plate (14). Tighten Hex head bolts (8) M6x30, M6x18 to 8 Nm. Install leaf spring (142) with retainer (141), tighten bolts (140) to 8 Nm. Assure that the locating pin for the retainer (72) is installed properly.

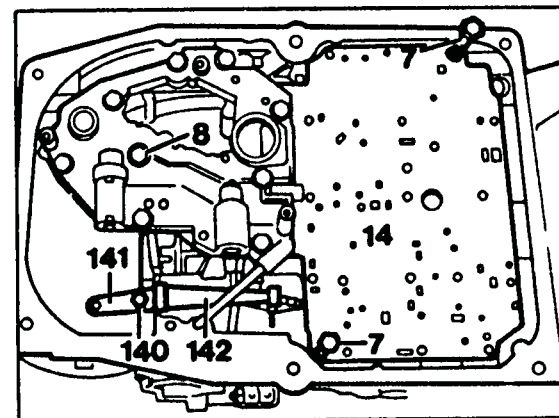



Technical Service Information

VALVE BODY CONTINUED

6-Press both tabs (arrows) of injector (118) together and remove.

7-Pull out oil tube (9).

8-Screw out mounting screws (8), remove cover plate (12) together with intermediate plate.

9-Detach gasket (19) from intermediate plate. Tightening torque for mounting screws (8) AM5x16 tighten 4 Nm.

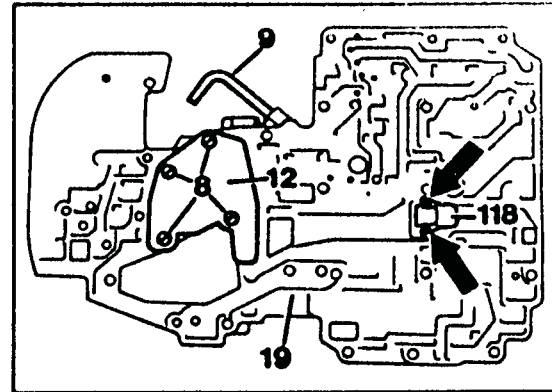

10-Screw out mounting screw (arrow) and remove kick-down solenoid valve (Y3/1y1).

INSTALLATION NOTE:

Check O-ring for damage, replace if required.

11-Remove plastic retainer (arrow) for regulation valve (Y3/1y2), for this purpose press regulation valve slightly into lower cover.

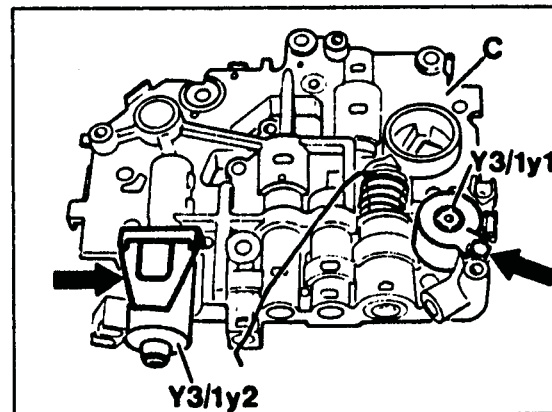



Technical Service Information

VALVE BODY CONTINUED

12-Disassemble lower cover, reassemble, check parts.

- 67 Check valve
- 88 Sieve filter
- 103 Drain valve KS
- 105 Drain valve LB2

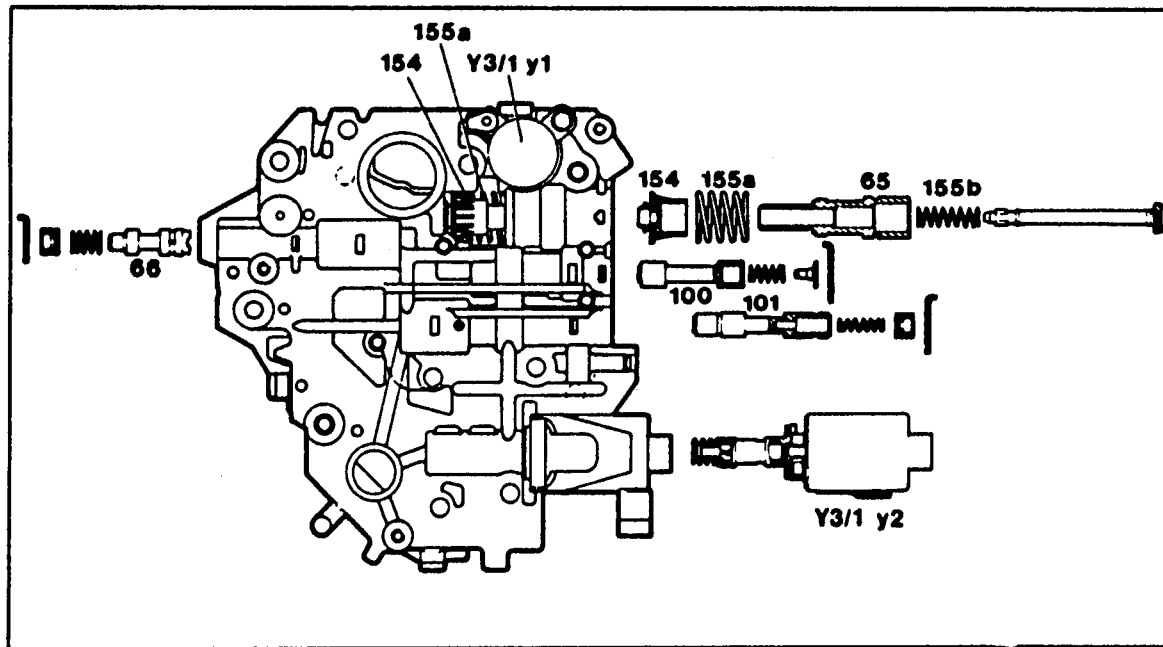
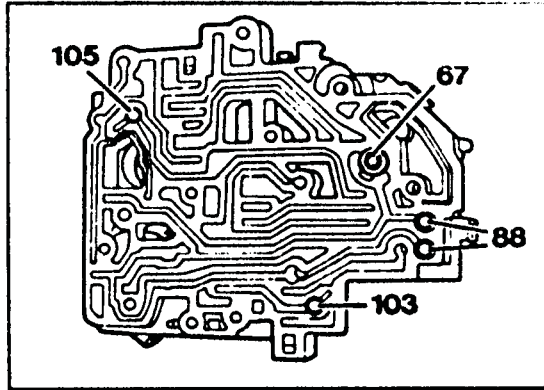

- 65 Lock-out piston (Rev,Kick-down)
- 66 Shift valve secondary pump
- 100 Shift valve overlap KS/BS
- 101 Regulator valve shift pressure BS
- 104 Pressure valve K2

- 154 Plastic sleeve
- 155a Return spring (large)
- 155b Return spring (small)
- Y3/1y1 Kick-down solenoid valve
- Y3/1y2 Regulator valve



Technical Service Information

GOVERNOR, REAR PUMP REMOVAL AND INSTALLATION

1-Screw out drain plug (4a) and drain oil.

INSTALLATION NOTE:

Tighten drain plug to 14 Nm. Check oil level and correct if necessary.

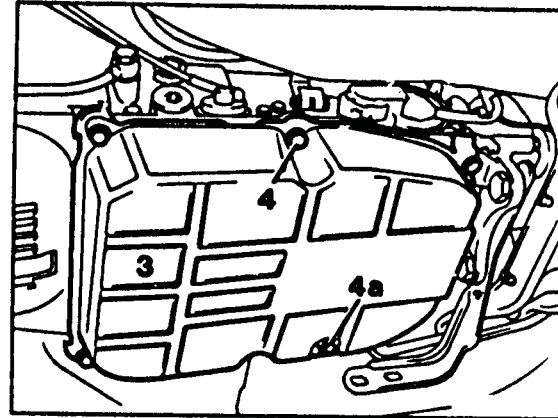

2-Remove cross member (22) together with rear engine mount.

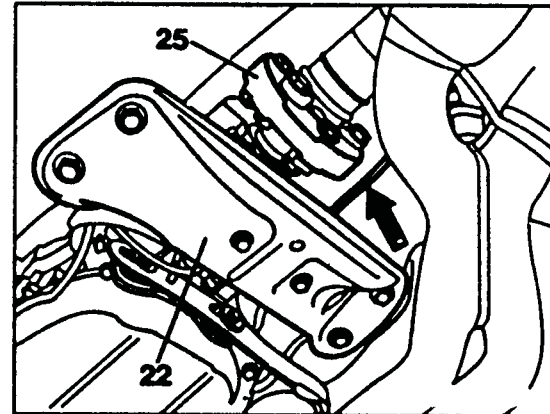

3-Remove companion plate (25).

4-Unplug lamda sensor cable (arrow) on tunnel and disconnect mounting clips.

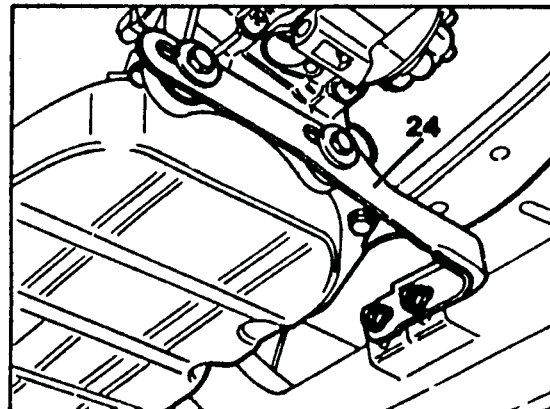

5-Completely remove exhaust support (24).



Technical Service Information

6-Screw out screw on pulse generator (L2) and pull out pulse generator

NOTE;

On vehicles with mechanical speedometer disconnect shaft.

7-Loosen plug (Y3/1x1) with a screwdriver and disconnect.

8-Completely disconnect exhaust system carefully lower and suspend with a V-belt.

9-Engage parking lock

10-Unscrew double hex nut with socket (015) and pull off flange.(Mercedes tool part number 126 589 02 09 00)

INSTALLATION NOTE:

Tighten torque 120 Nm, then bend collar into recess on output shaft with suitable punch.

11-Remove washer(65)

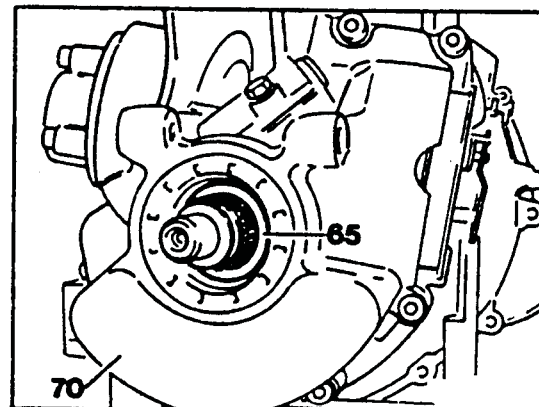
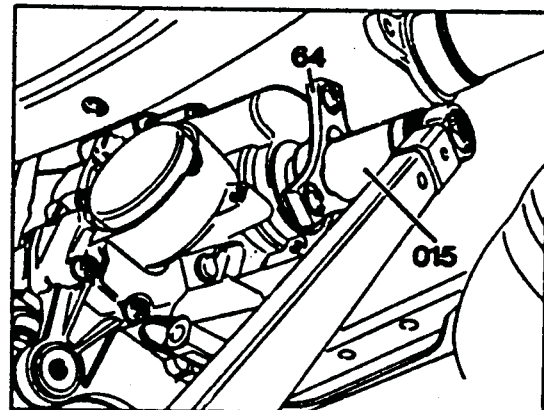
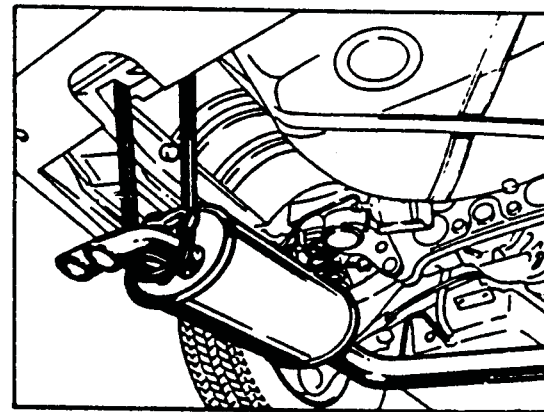
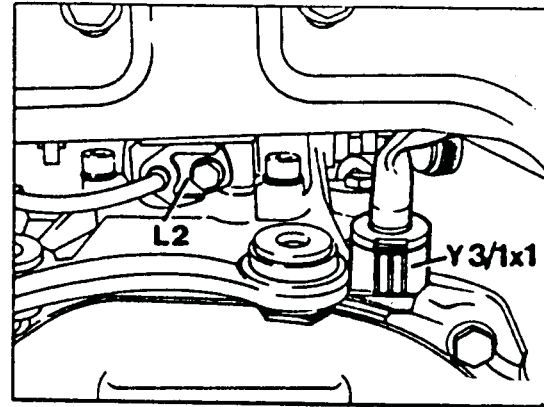



Technical Service Information

12-Screw out allen screw (45) and remove secondary pump (20)

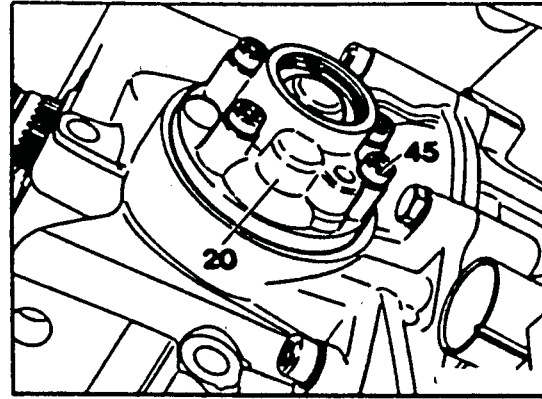

INSTALLATION NOTE

Tighten torque for M6x30 bolt is 8 Nm

13-Remove O-ring (22) and intermediate plate (21) for secondary pump.

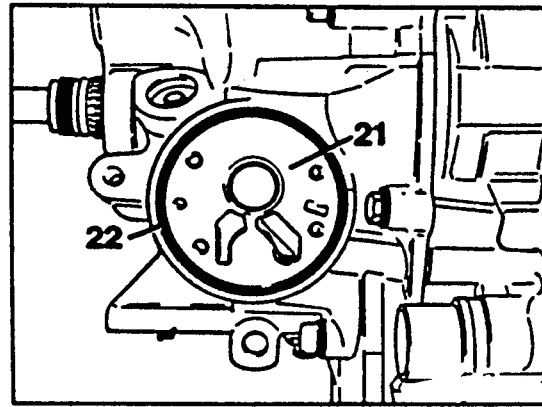

13a-Remove pump from housing.

13b-Remove retaining ring (28) and cover (27).

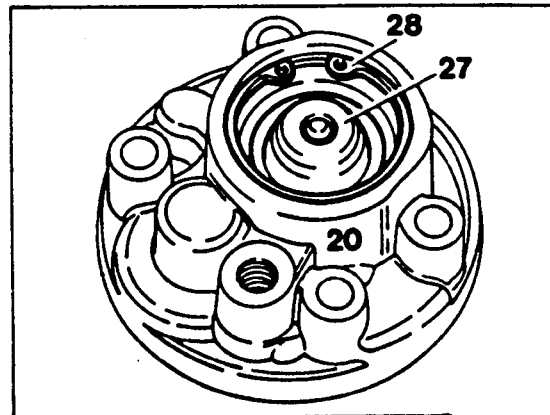

INSTALLATION NOTE:

Oil pump gears(22 and 23) and insert into pump housing. Insert driven pump gear (22) so that drive lug (arrow) points upwards.

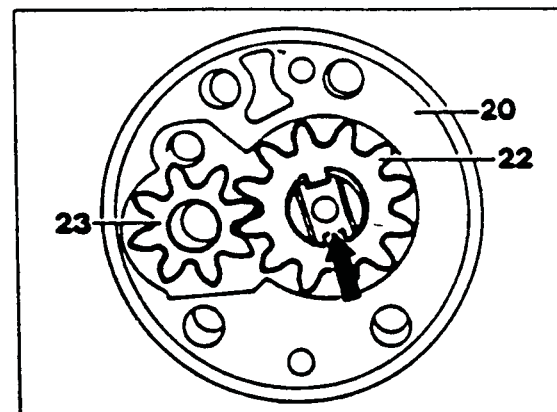



Technical Service Information

13c-Remove switch-off piston (21) together with pressure spring (24) and spring plate (25) from transmission.

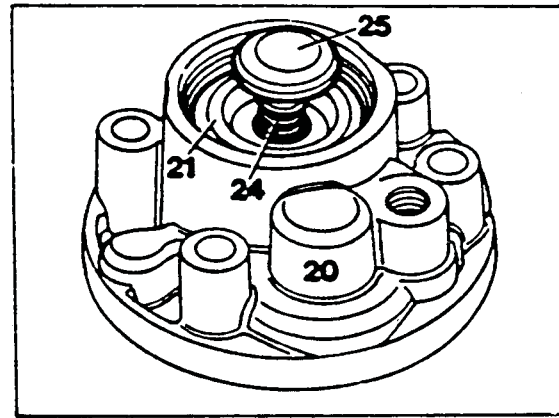

13d-Remove O-ring (29). Check all parts for damage and wear. The gap in the two teflon rings (30 and 31) should beall the way together, no gap, if necessary insert teflon ring into grooves with a small quantity of grease.

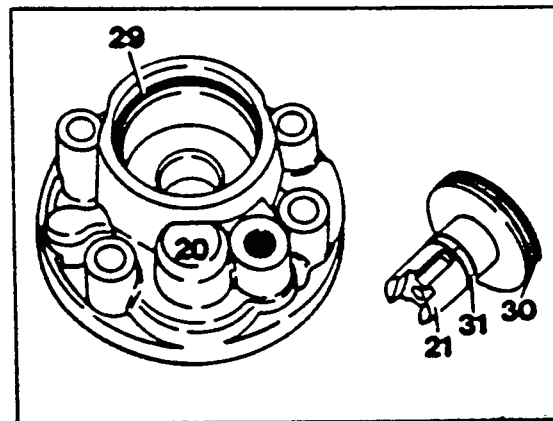

14-Press cover (46) pf governor in to move retaining ring (47) and remove cover.

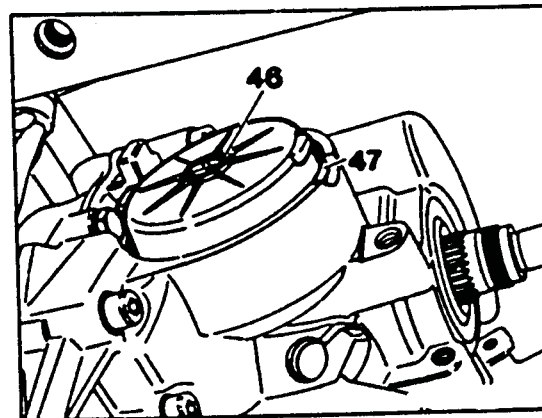

INSTALLATION NOTE :

After installation pull cover out so that it contacts the retaining ring around entire circumference.

15-Turn output shaft so that governor (50) is in position shown in illustration.

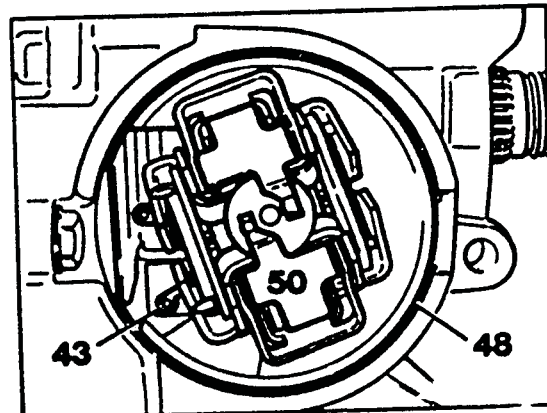



Technical Service Information

16-Insert snap ring pliers in position illustrated press retaining ring together and pull governor out of case as far as possible.

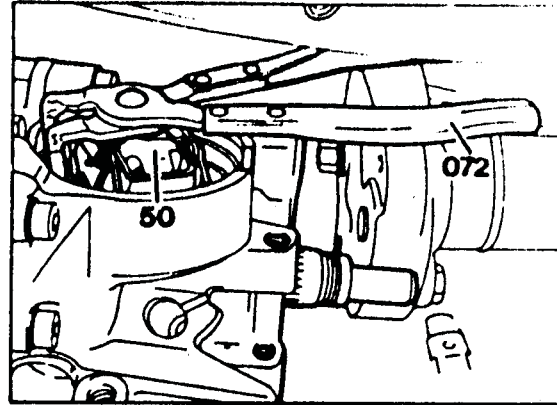

17-Remove pliers (072), press against right side of transmission and remove governor.

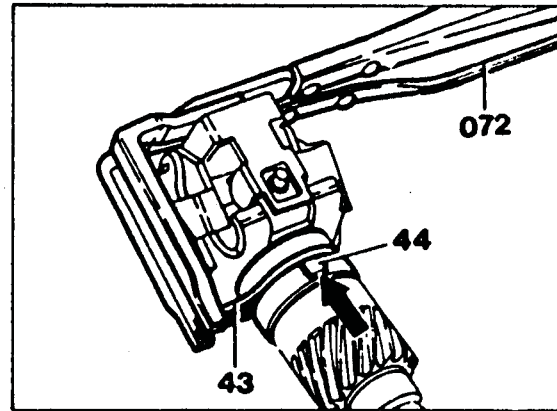

INSTALLATION NOTE:

Turn transmission to right and insert governor with pliers pressed together. The nose (arrow) must be inserted into the groove in the housing (arrow).

CAUTION

Be sure that the retaining ring is seated in the annular groove. When the governor is installed properly the retaining ring can be moved back and forth easily in the annular groove.

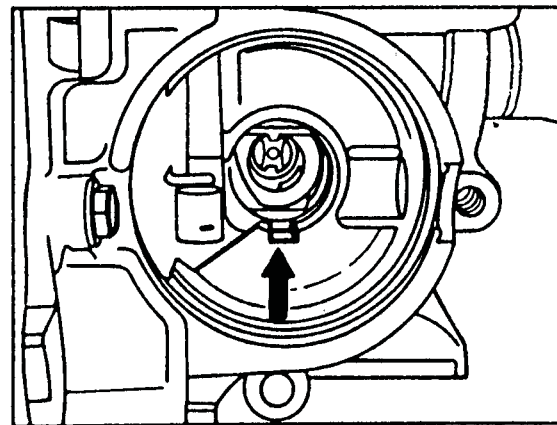



Technical Service Information

17a-Remove retaining ring (40), and pull of pinion (41).

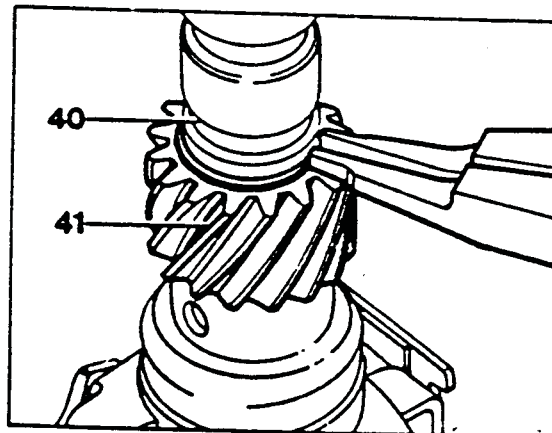

INSTALLATION NOTE:

Position pinion (41) so that the drive pin (arrow) engages in the hole in the pinion.

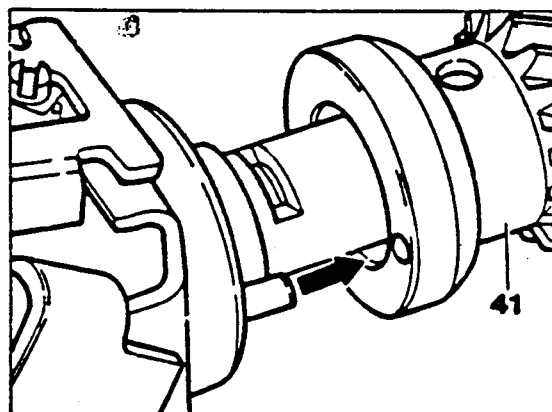

17b-Move centrifugal weights (f) and check control valve for easy motion in openings (arrows).

NOTE:The control valve must be easy to move, wash out and blow out governor as required. If it is not possible to free up the control valve in this manner, then replace the governor.

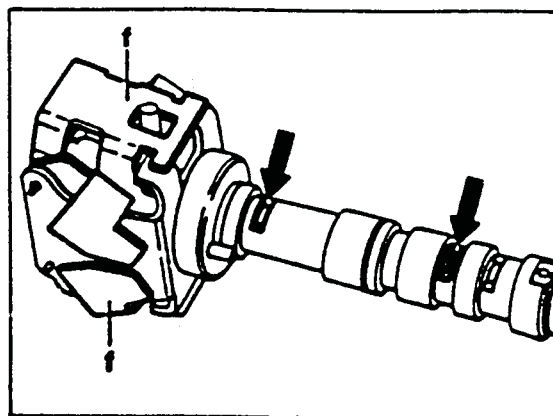



Technical Service Information

18-Screw out hex bolts (2 each) and allen screws (7 each) (71).

19-Loosen rear cover (70) with plastic hammer and remove while pressing the output shaft (86) into the housing

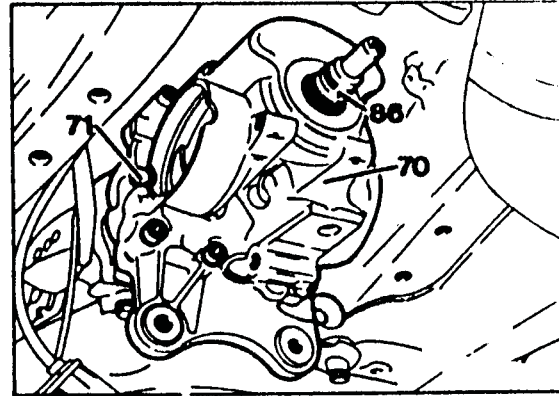

CAUTION:

Do not pull output shaft out of housing under any circumstances. The ring gear and the clutch element can no longer be pushed back into the clutch discs making it necessary to remove the transmission.

INSTALLATION NOTE:

Check seal for damage. It can generally be reused, however it should not be coated with sealant. Tightening torque for M8x55 allen screws and 8x35 hex head bolts is 13 Nm.

NOTE:

Degrease screws and coat with non-hardening sealer.

20-Install shims (163) on output shaft (86). It is possible for the shims to stick on the ball bearing in the rear cover.

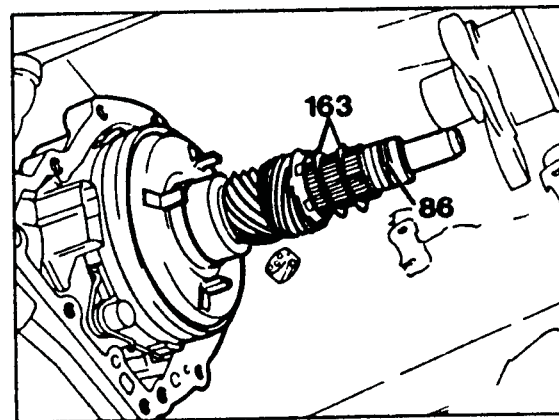



Technical Service Information

21-Pry out radial seal (66) with a screw driver.

INSTALLATION NOTE:
Install with suitable driver.

22-Remove retaining ring (68) and knock out ball bearing.

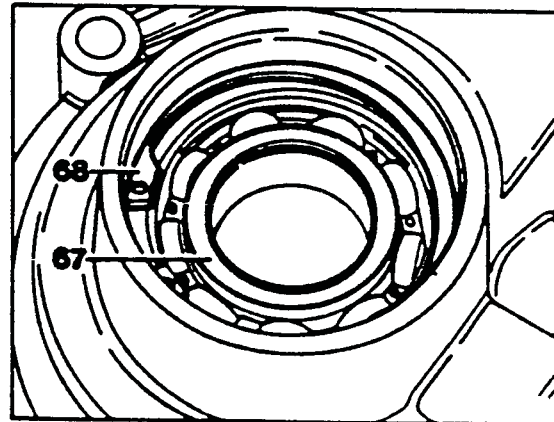
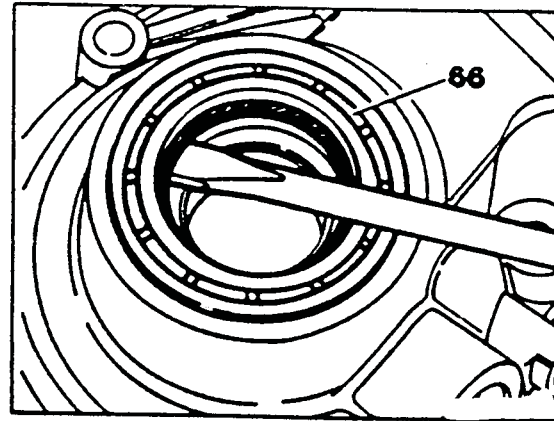

INSTALLATION NOTE:

Play should not be present between the retaining ring (68) and the ball bearing (67). For this reason retaining rings are available in three different thickness' (2.0-2.1-2.2mm). When inserting the retaining ring be sure that it is positioned properly in the groove. If the retaining ring cannot be inserted, use a thinner retaining ring. If play is present between the retaining ring and the ball bearing use a thicker retaining ring. Check whether play is present with a feeler gauge (0.10mm).

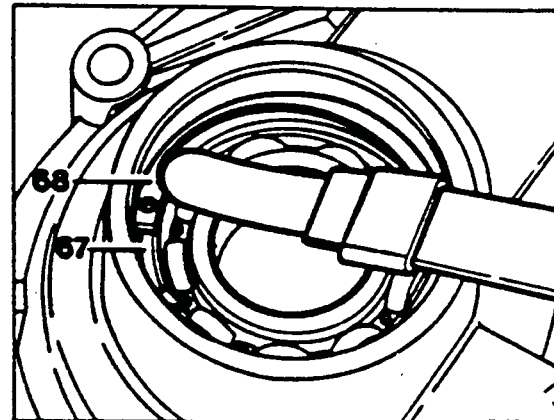



Technical Service Information

23-Drive shaft (130) upwards toward cover (127) and out of housing with suitable drift.

INSTALLATION NOTE:

Press cover (127) into housing until play of 0.5mm is present for the small drive gear.

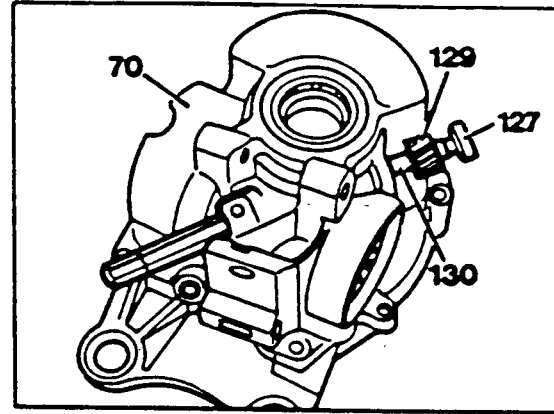

24-Pry radial seal (132) out of rear transmission housing (70).

NOTE:

To facilitate removal screw an M12 hex bolt into the radial seal and clamp in a vise. Tap lightly against transmission cover with a plastic hammer while pulling out radial seal.

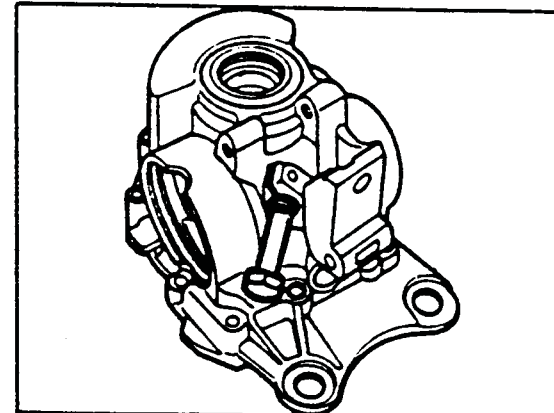

INSTALLATION NOTE:

Carefully press in radial seal (132) against stop with punch.

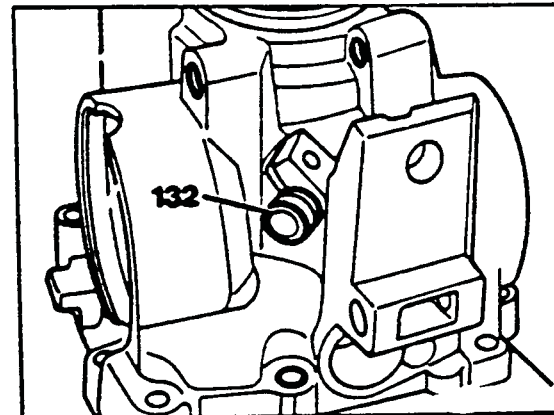

25-Unclick cover for oil reservoir (160).

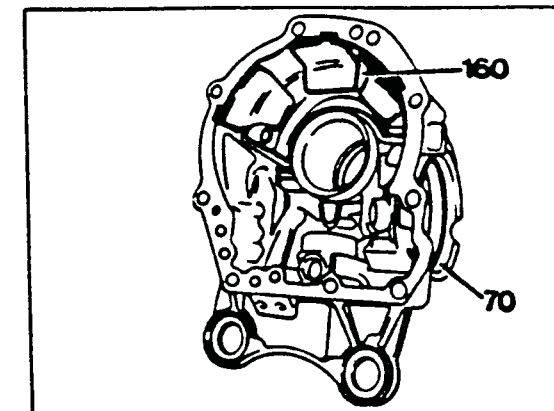



Technical Service Information

REMOVAL AND INSTALLATION OF TRANSMISSION

1-Disconnect negative cable from battery.

2-Screw off holder (arrow) for oil filler tube (28) on cylinder head.

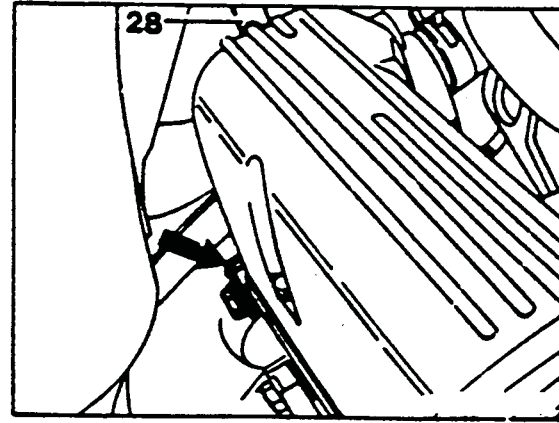

3-Press both tabs on plastic clip (18) together with pliers and pull out control cable for control pressure in direction of arrow.

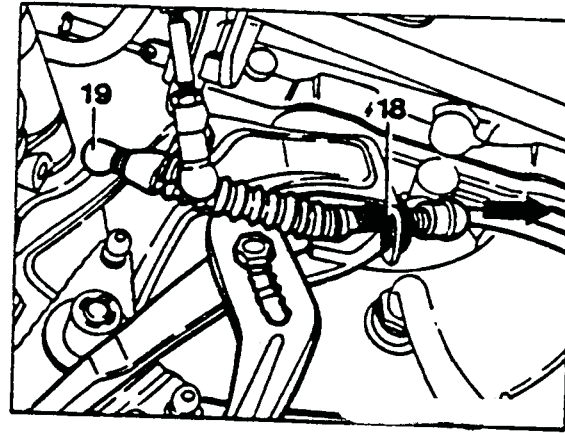

INSTALLATION NOTE:

Adjust control cable for control pressure.

4-Jack up vehicle.

5-Screw out drain plug (4a) in oil pan and drain oil.

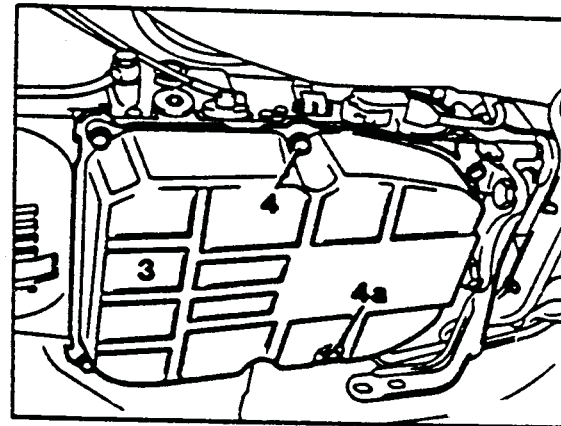

6-Screw out drain plug on torque converter (2) and drain fluid.

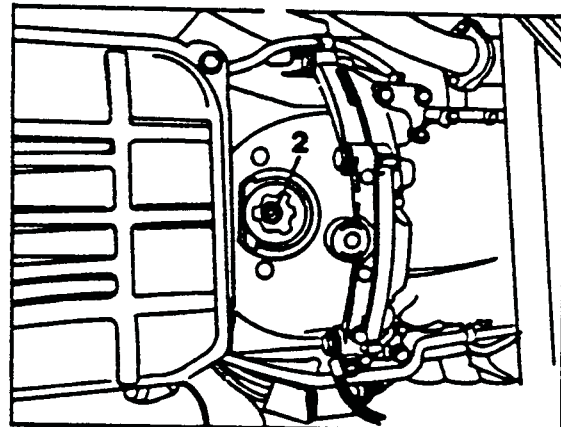

INSTALLATION NOTE:

Screw drain plugs into oil pan and torque converter and tighten to 14 Nm.



Technical Service Information

7-Remove plastic cover (16).

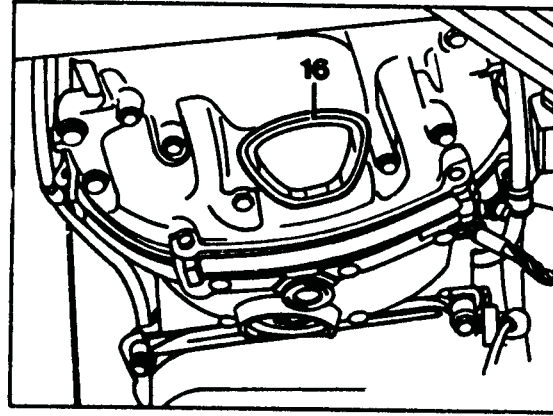

8-Screw out bolts (17) on drive plate for torque converter (total 6 each).

INSTALLATION NOTE:
Tightening torque M8x14 is 42 Nm.

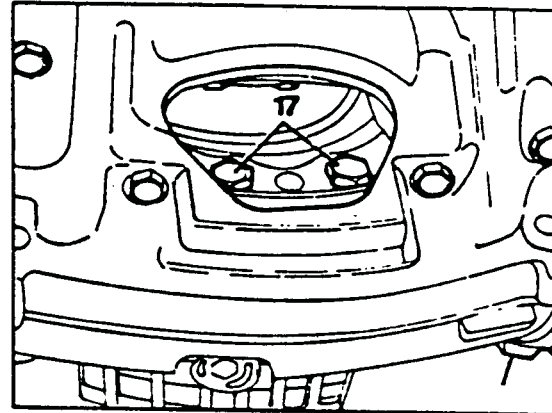

9-Remove cross member (22) together with engine mount.

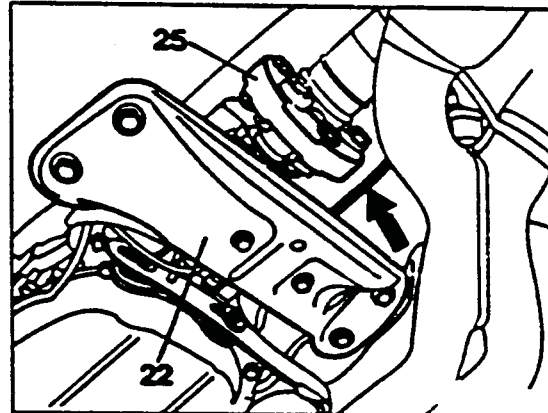

10-Disconnect companion plate (25) from universal flange.

11-Disconnect lambda sensor cable (arrow) on tunnel and detach mounting clips.

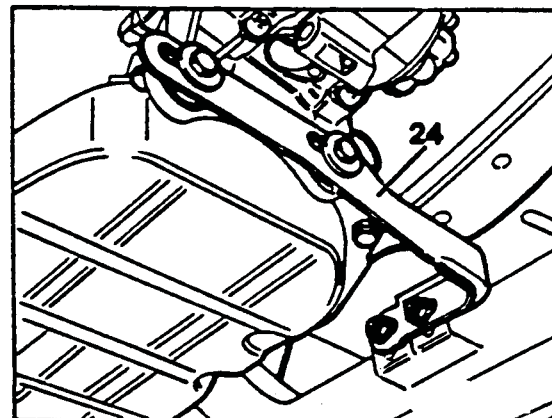

12-Completely remove exhaust support (24).

AUTOMATIC TRANSMISSION SERVICE GROUP



Technical Service Information

13-Screw out screw on pulse generator (L2) and pull out pulse generator (Vehicle speed sensor VSS).

NOTE:

On vehicles with mechanical speedometer disconnect shaft.

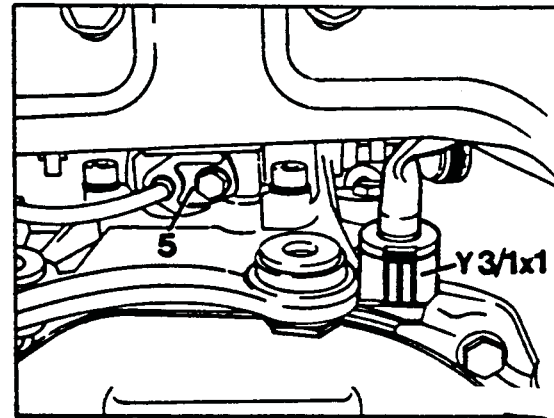

14-Disconnect plug (Y3/1x1) with screw driver and pull off.

15-Disconnect cable from solenoid valve for shift point increase (X22/7).

16-Disconnect transmission overload switch cable (X22/6) and pull off vacuum line (10).

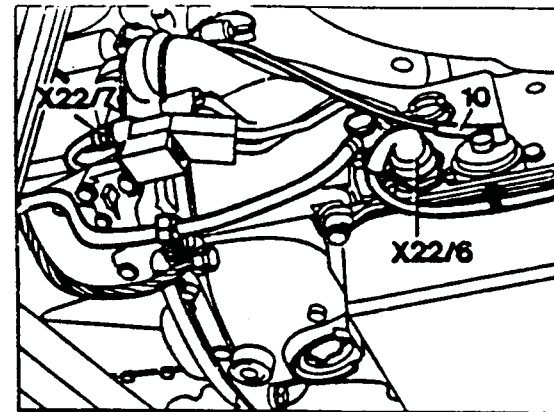

17-Remove plug for starter lock-out switch (8).

CAUTION:

The plug for the starter lock-out switch is secured by a lock (white plastic ring). Before pressing off the plug, the lock must be turned up (direction of arrow). Carefully pry off plug with two screw drivers under cable exit and the tab.

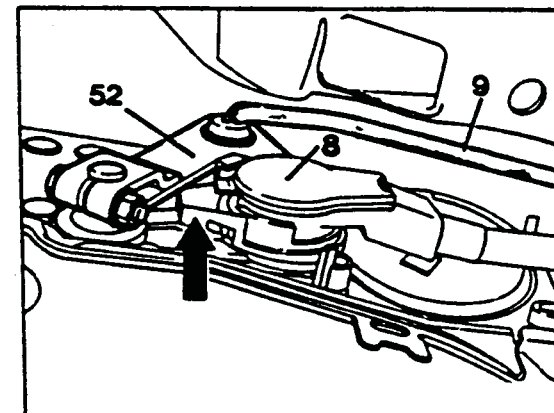

18-Disconnect shifting rod (9) on range selector lever (52).

19-Completely detach exhaust system, carefully lower and suspend with a V-belt.

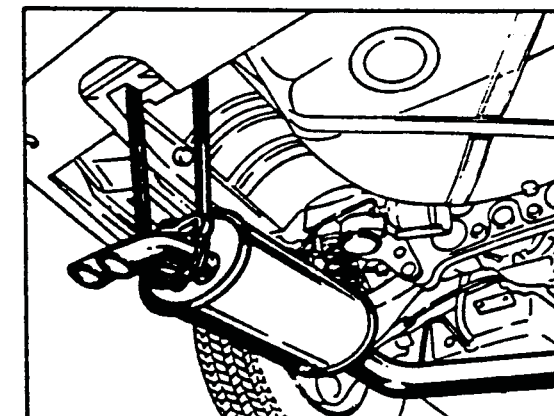



Technical Service Information

20-Disconnect oil cooler feed line and oil cooler return line (13).

INSTALLATION NOTE:

Replace gaskets for feed and return lines.

21-Screw our mounting screw (14) for oil filler neck (15) and push oil filler tube up.

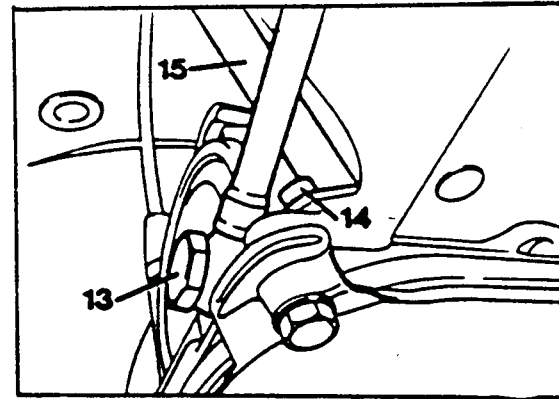

23-Screw out all mounting screws (21) except for the two screws on the side (35).

INSTALLATION NOTE:

Tightening torque is 55 Nm.

24-Slightly jack up transmission.

25-unscrew remaining bolts.

26-Slide transmission to rear as far as drive shaft permits and lower jack carefully.

INSTALLATION NOTE:

Lift transmission to engine height and slide forward until torque converter housing is against engine. Reconnect ground strap (36)

27-Lift transmission off of Jack.

INSTALLATION NOTE:

Turn torque converter so that one of the three threaded plates points straight down. Slightly grease centering pin on converter.

28-Set Transmission in vertical position.

29-Turn plastic retaining pin (arrow) for converter 1/4 turn counter-clockwise with 8mm allen wrench and remove.

30-Screw bracket onto converter as illustrated.

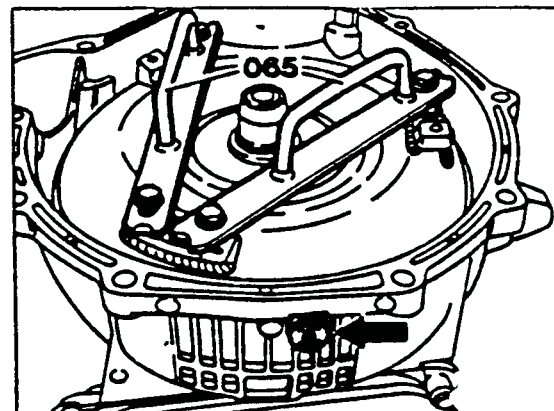
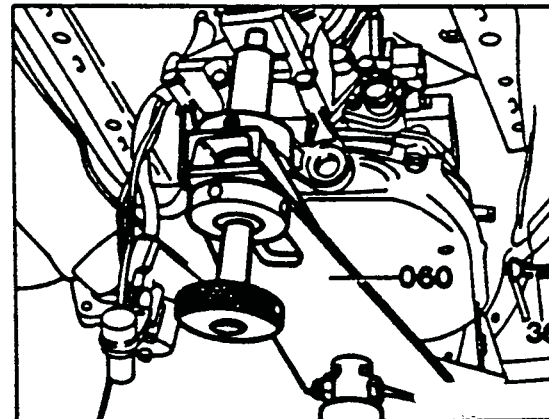
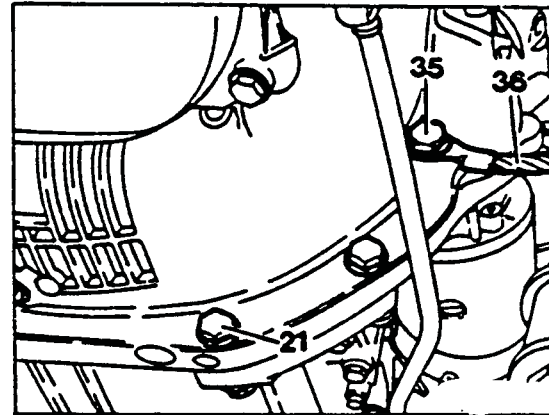



Technical Service Information

31-Pull out torque converter.

INSTALLATION NOTE:

Grease drive flange (32) and crankshaft bearing journal with molycote. Turn torque converter back and forth when installing to allow teeth to mesh. Insert plastic retaining pin (arrow) and turn 1/4 turn clockwise.

If the transmission oil pan contains metal chips, replace the torque converter. Metal chips cannot be completely removed by flushing the torque converter.

32-Flush torque converter by adding 1 liter of kerosene. Insert flushing mandril (063) (mercedes tool number 116 589 00 15 00) and operate at a low speed for approximately 2 minutes. Then drain kerosene by removing drain plug. Repeat this procedure 3-4 times until kerosene flowing out is clean.

33-Screw oil cooler to syringe (064) (Mercedes tool number 112 589 00 72 00) and flush with kerosene. Then blow out oil cooler lines and oil lines.

34-Add transmission fluid through filler neck. When the transmission is at operating temperature (80° C.) the oil level should be at the maximum mark (arrow).

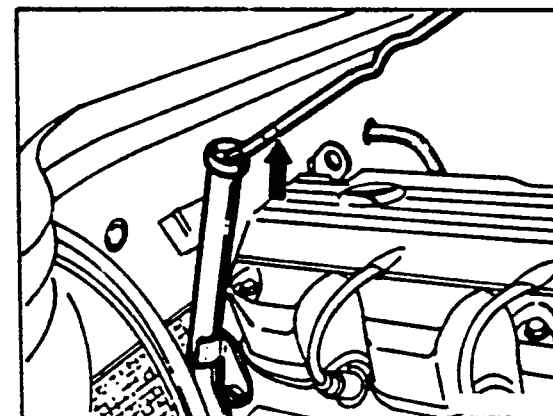
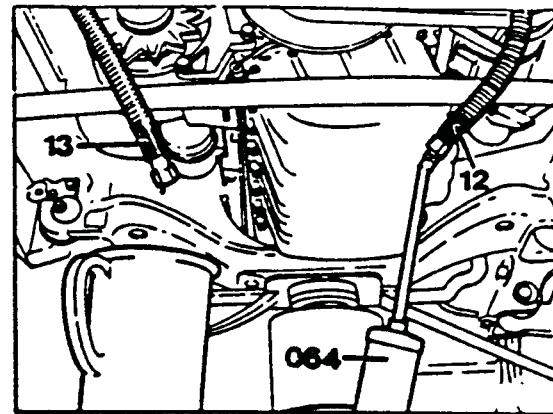
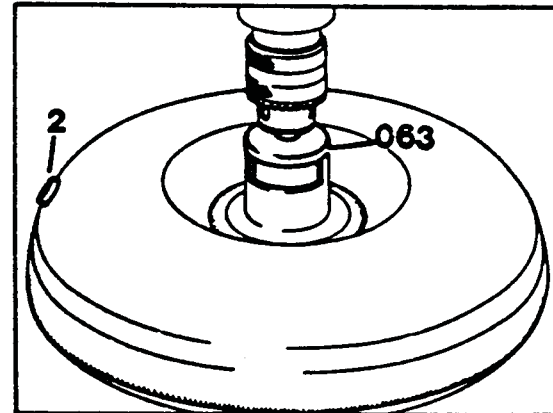
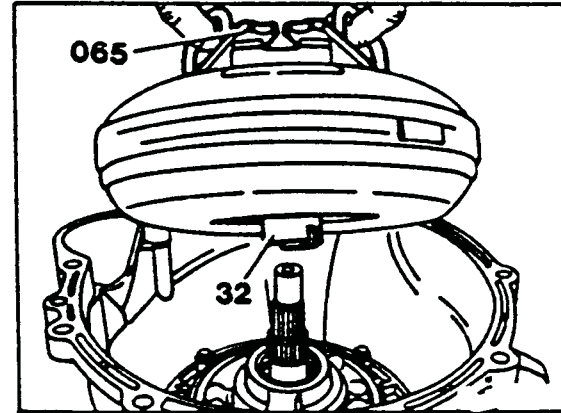



Technical Service Information

TRANSMISSION TEARDOWN AND ASSEMBLY

1-Remove pump bolts.

2-Screw two bolts into threaded holes (arrows) and use these to pull out front pump (10)

INSTALLATION NOTE:

Clean surfaces replace pump gasket do not use any sealant on the gasket. The bolts should have a non-hardening sealant torque bolts to 13 Nm.

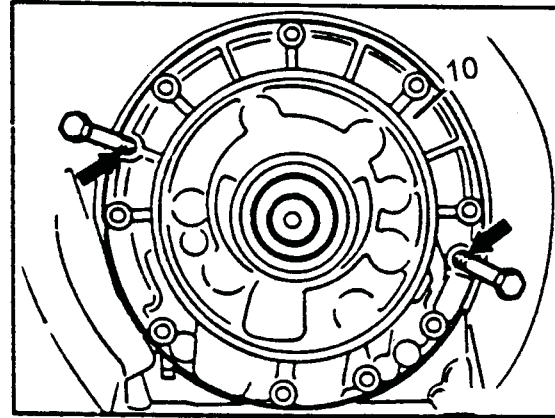

3-Remove the two teflon rings (9).

INSTALLATION NOTE:

Insert teflon rings (9) with grease. Assure that the ring gaps (arrows) remain together. If necessary remove rings again and reform to smaller diameter.

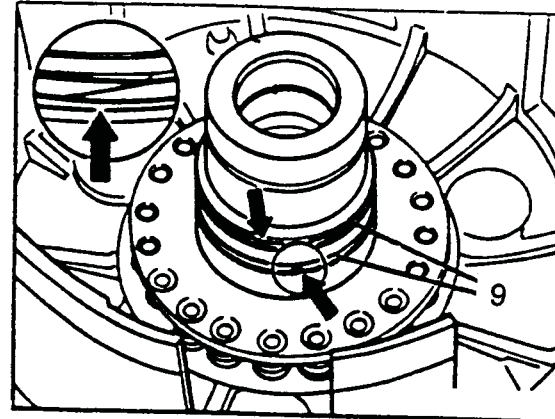

4-Position installation fixture (020) on spring plate (13) and clamp until snap ring (15) is exposed. Remove snap ring (15). Release installation fixture and remove.

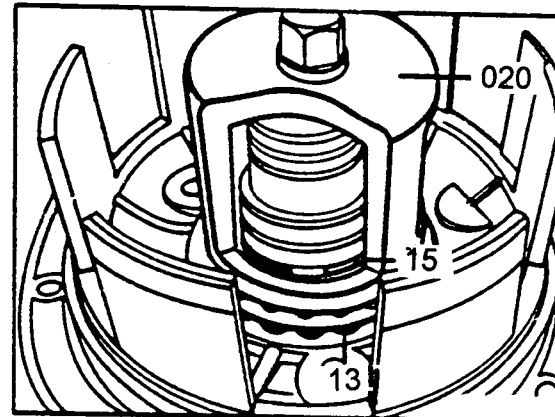

5-Remove spring plate (13) and return springs (14) for piston B3.

INSTALLATION NOTE:

Number of return springs = 20.

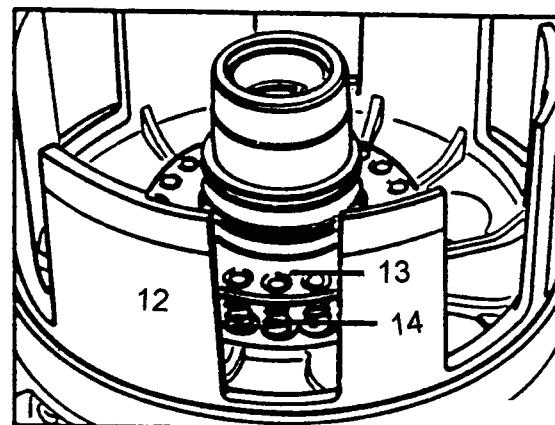



Technical Service Information

6-Pull out B3 Piston (12).

INSTALLATION NOTE:

Replace lip seals (16,17). the lip seals must be installed so that the lips point toward the rear (direction of arrow).

Apply oil to to sliding surfaces for lip seals. Insert piston (12) so that the pin (on the piston) and the hole (ib the pump cover) coincide. Carefully press piston in housing without crimping seal. Remove installation sleeve (024).

7-Loosen mounting bolts (8) and screw out.

8-Remove primary pump from front cover.

INSTALLATION NOTE:

Insert mounting screws (8) M8x32 and tighten to 20 NM.

9-Remove both pump gears (3,4) from pump housing.

INSTALLATION NOTE;

Oil both pump gears (3,4) and position in pump housing, Insert pump gear (4) so that the bevel (arrow) points toward the radial roller bearing (20)

CAUTION:

If radial roller bearing (20) is damaged replace front pump.

10-Replace radial seal (front pump)(6).

11-Replace O-ring (7). Insert O-ring into groove on pump assembly.

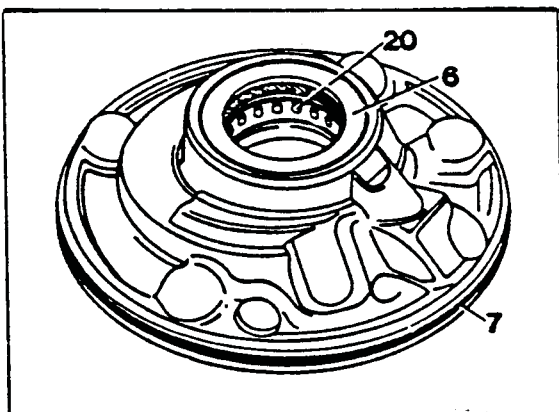
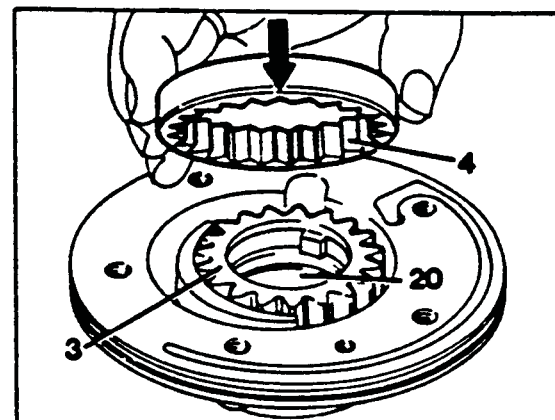
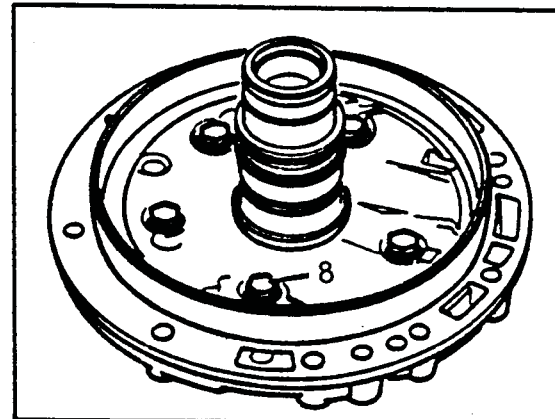
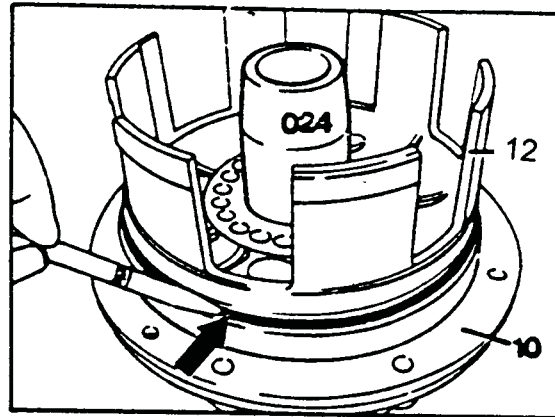
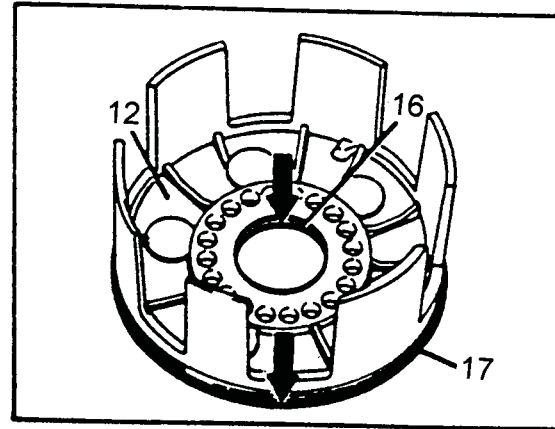



Technical Service Information

TEARDOWN;

1-Remove control pressure cable. Release lock with screw driver (arrow) and unhook control pressure cable.

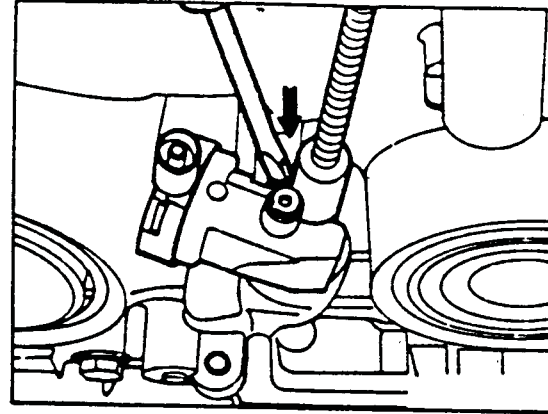

NOTE;

On vehicles with catalytic converter screw off switch-over valve for increasing shift point (Y3/2) complete with pressure oil line.

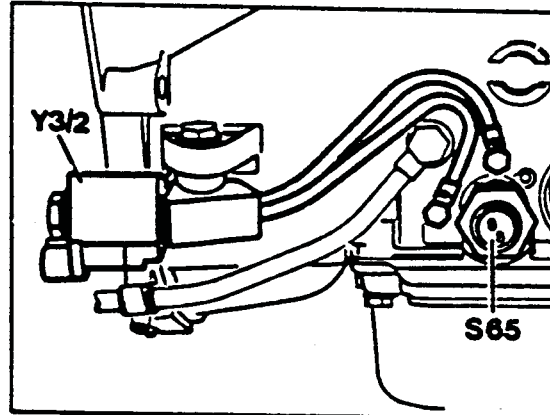

2-Place transmission in holding fixture. Position transmission as shown in illustration.

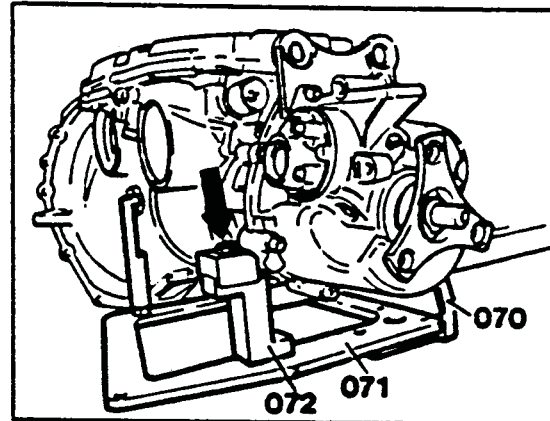

3-Remove bolts (4) and remove transmission oil pan (3).

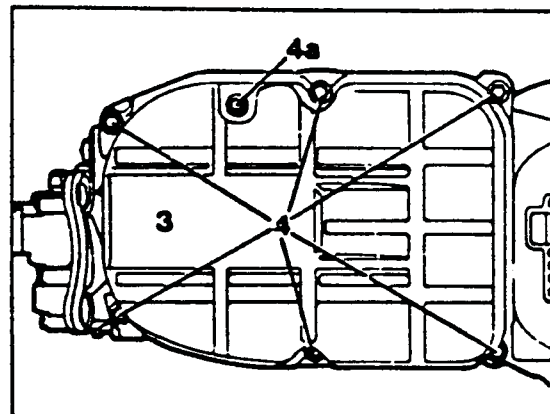

AUTOMATIC TRANSMISSION SERVICE GROUP



Technical Service Information

4-Remove phillips screws (6) and remove oil filter(5).

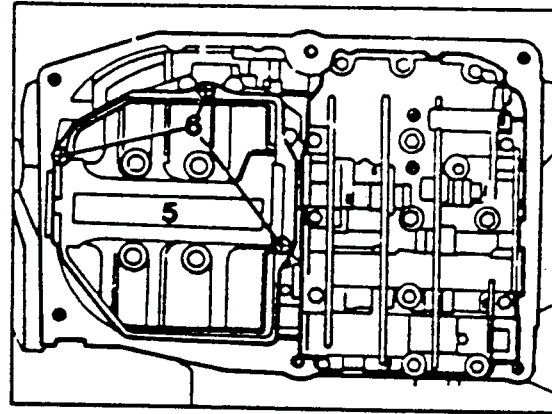

5-Remove hex head bolts (7) and (7a) and remove valve body assembly (A).

Disassemble valve body, refer to valve body section.

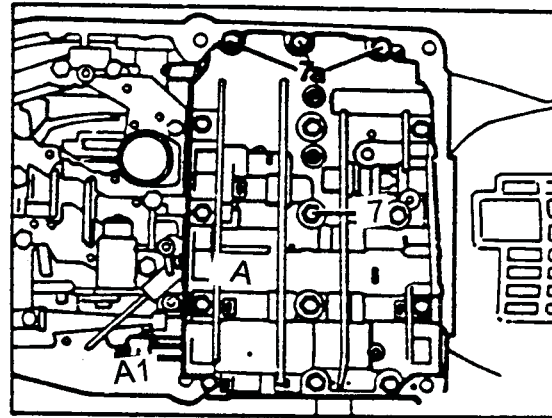

6-Turn adjustment and retaining screw (151 to right with screw driver and unhook connecting rod (150).

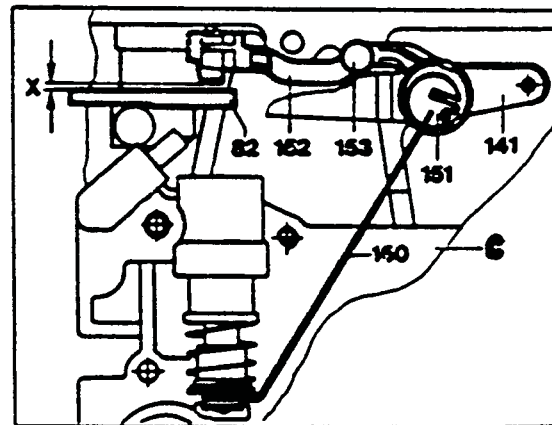

7-Pivot locking lever (152) over lock plate (82).



Technical Service Information

8-Remove hex head bolt (140), remove holder (141) with catch spring (142) and locating pin (135).

9-Remove clamping screws (139) and hex bolts (8).

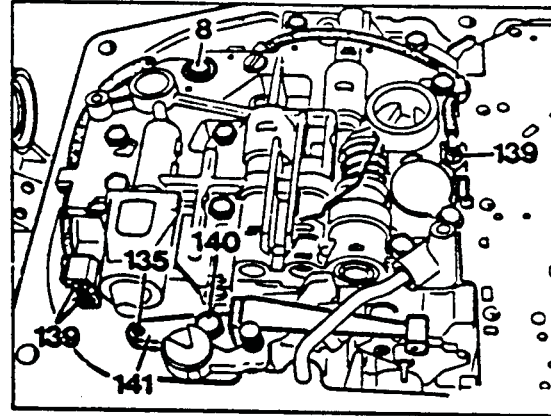

10-Remove bottom cover (13) together with intermediate plate (14) and oil tube (9).

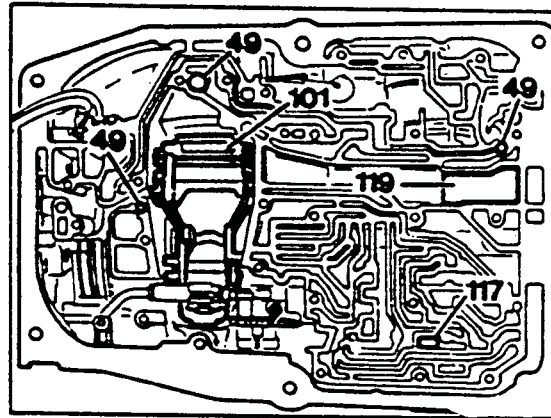

11-Remove one-way valves (49), brake band guide B2 (101), oil deflector (119) and temperature throttle (117).

12-Press in brake band piston cover B2 (17), remove retaining ring (23) and remove brake band piston cover.

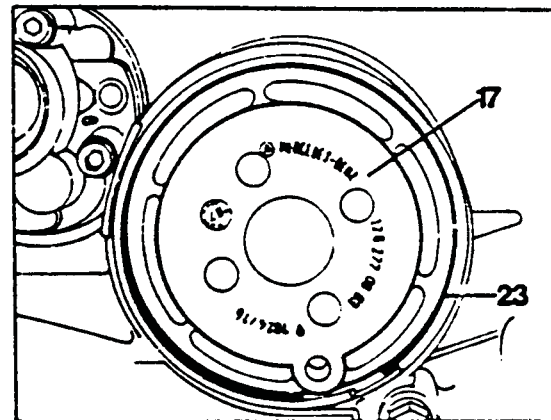



Technical Service Information

13-Pull out brake band piston B2 (15) with thrust pin (26) clipped in.

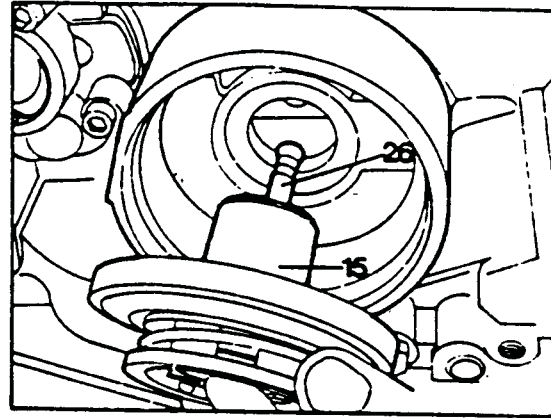

14-Attach assembly device (026) (Mercedes tool 201 589 03 69 00) and screw into transmission housing.

15-Clamp assembly device and remove retaining ring (41).

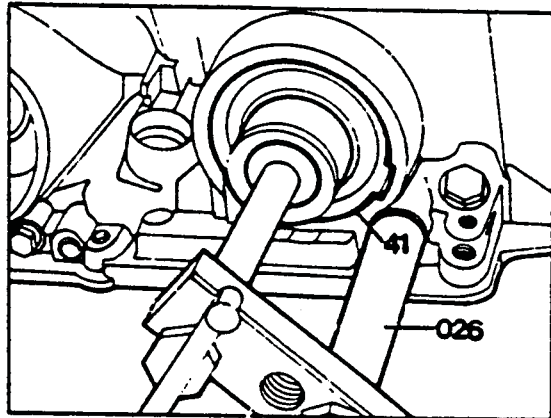

16-Release assembly device (026), remove brake piston B1 (37) together with thrust pin, as well as cover (40) and return springs (35,36).

17-Remove release assembly device.

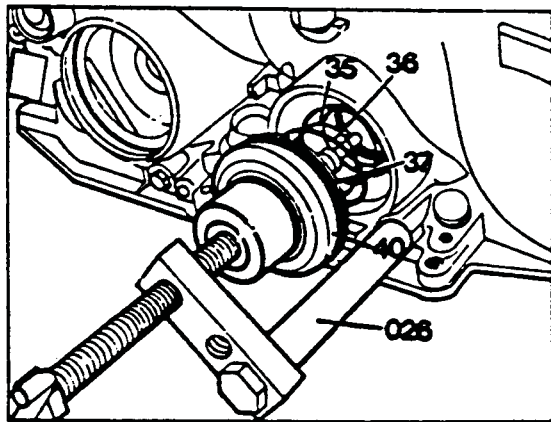

18-Pull out brake band guide B1 (34).

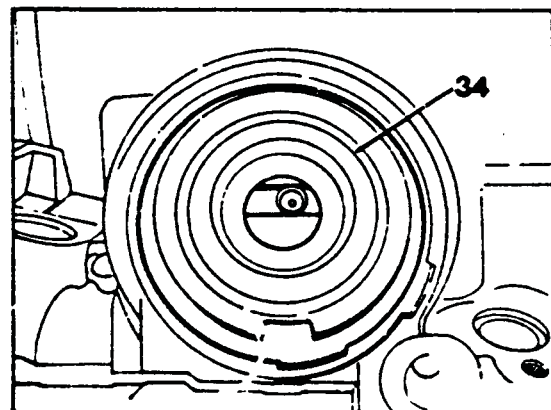



Technical Service Information

19-Screw out pressure switch for transmission overload protection (S65) and remove thrust element B1 (31).

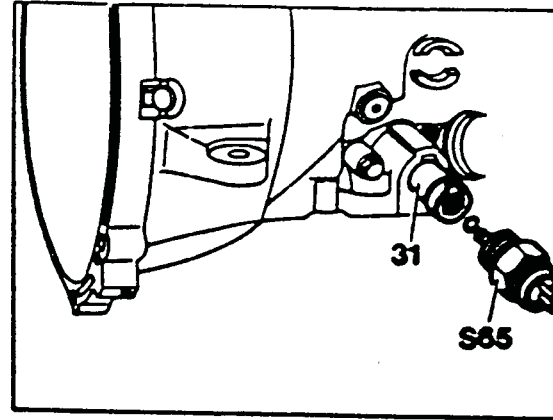

20-Remove hex bolt (51) and pull of range selector (52) (Manual lever position sensor).

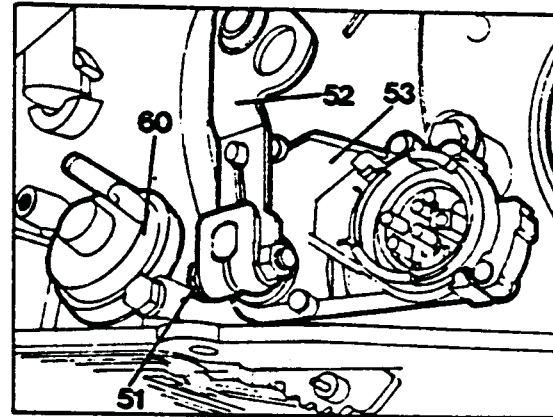

21-Remove hex head bolt (55) and remove starter lock-out switch (53).

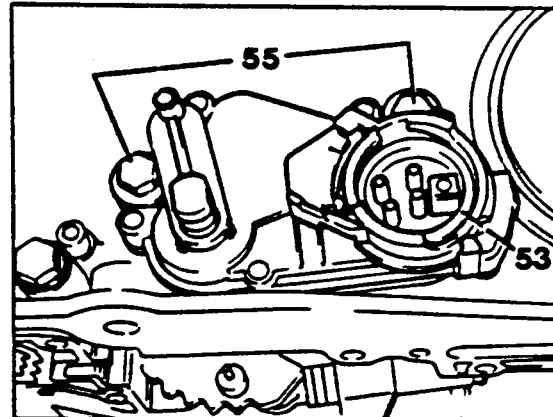

22- Remove vacuum control unit (60) after removing allen screw.

23-Remove heat expansion pin (59a) and modulator pressure control valve (59)

24-Remove brake, high gear (BS).

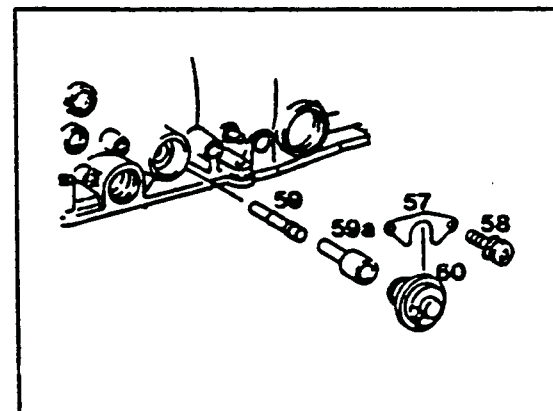



Technical Service Information

25-Pull off parking pawl (74), spreading spring (75) and plastic guide (80), then remove roller (81).

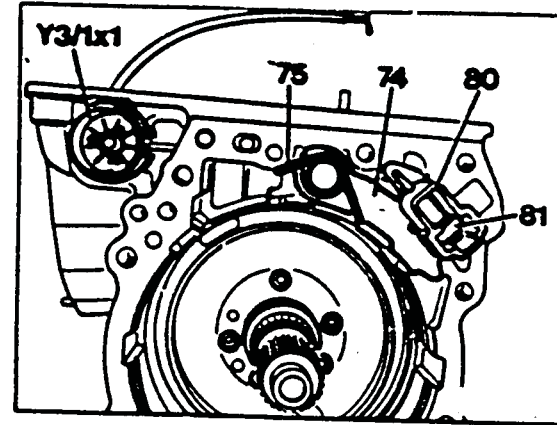

26-Remove 9 pole round plug (Y3/1x1) from housing together with cable.

27-Remove combination screws out of front cover.

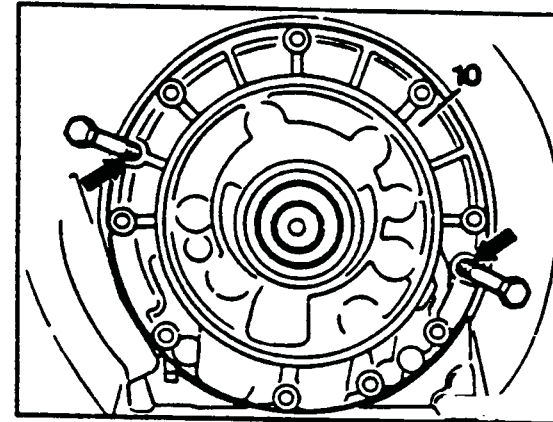

28-Screw two bolts into threaded holes (arrows) and use to pull out front pump assembly. refer to teardown section on pump assembly.

29-Grip planetary gear set on input shaft (87) and carefully pull out toward front.

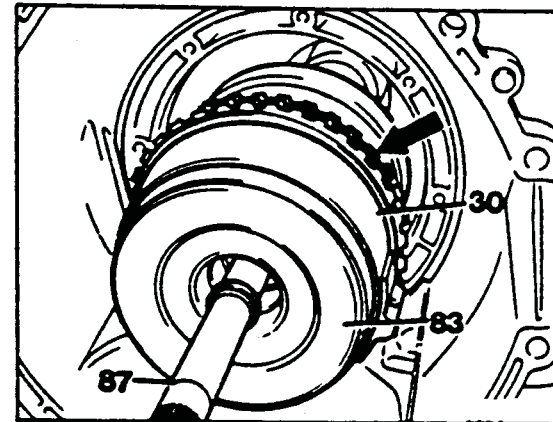

30-Pull clutch K1 (83) off of planetary gear set together with brake band B1 (30).

31-Remove plates for B3 assembly (arrow).

32-Remove damping spring (134).

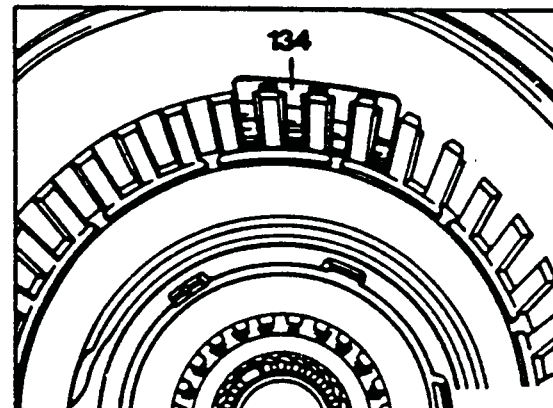



Technical Service Information

33-Remove clutch K2 (100).

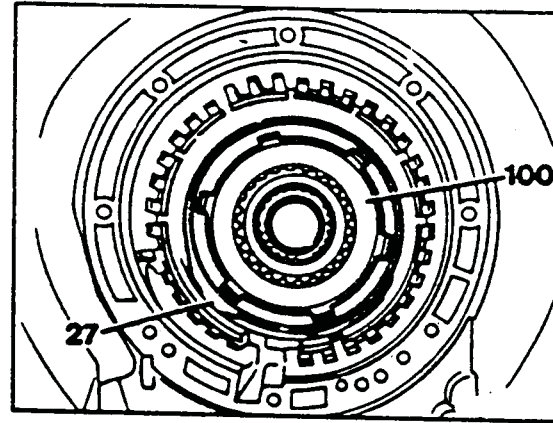

34-Remove allen screw (82a), pull out shaft (76) and remove catch plate (82) with rooster comb linkage.

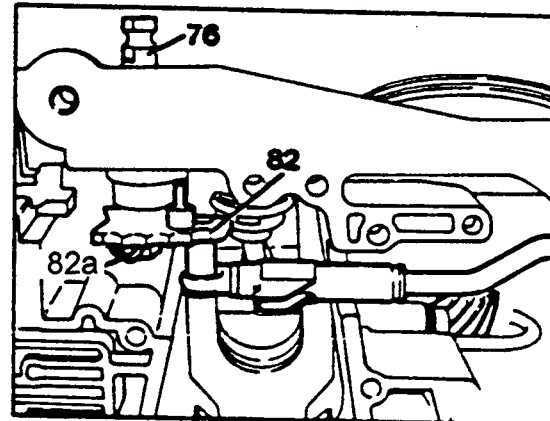

35-Remove thrust pin (28).

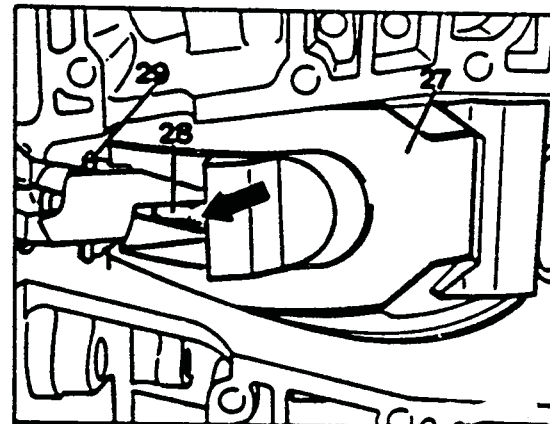

36-Position brake band B2 (27) at angle, press together and remove.

NOTE:
Lateral cracks in brake band lining have no effect on function.

37-Pull out thrust element B2 (29).

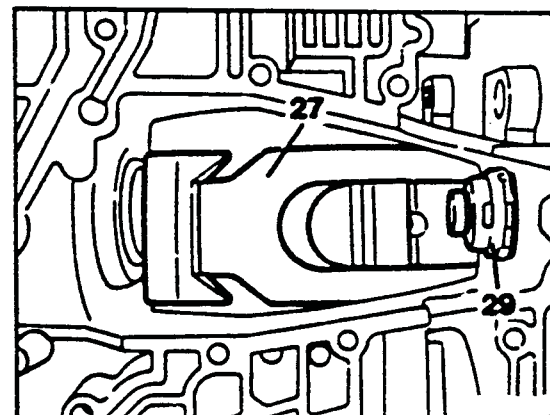



Technical Service Information

38-Remove thrust washer K2 (113) from support flange (79).

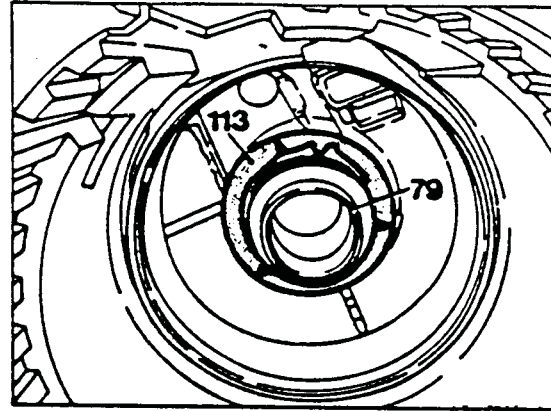

39-Remove allen screws (114) and remove support flange (79) from housing with plastic hammer.

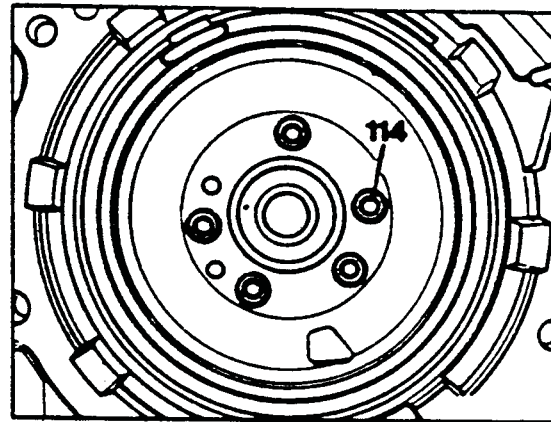

40-Remove sealing rings, test connection plugs etc, still in housing, Remove housing from assembly holding fixture.

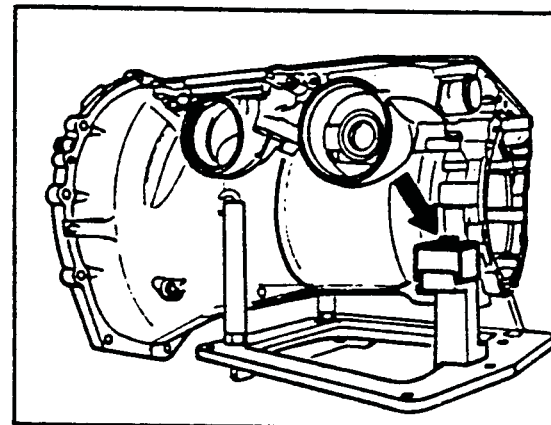

ASSEMBLY:

NOTE:

Clean case, soak friction materials clutches bands etc in transmission fluid for at least 1 hour before reassembly.

41-Re-install transmission case in holding fixture.



Technical Service Information

42-Insert guide ring (88a for piston B2), then install lip seal (88) with bushing or seal driver. The sealing lip (arrow) should point in the direction of the brake band piston cover.

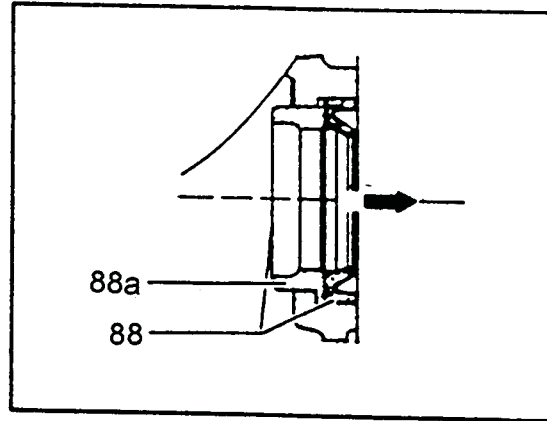

43-Insert O-ring (91) into groove.

44-Insert radial seal (92).

45-Install plug (90) with new aluminum gasket and tighten to 10 Nm.

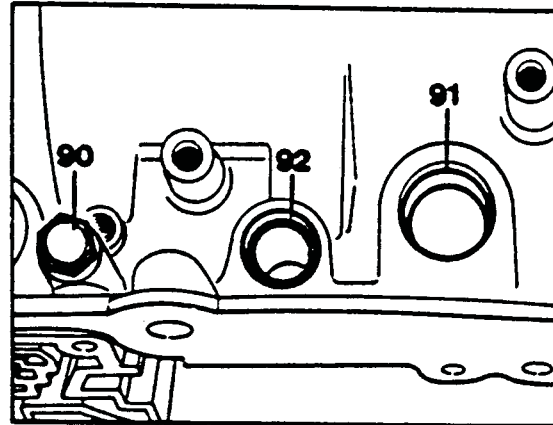

46-Coat groove in support flange K2 (79) with grease. Insert teflon rings (115) and press into groove until gap (arrow) remains closed. Insert O-rings (197) and moisten slightly with transmission fluid.

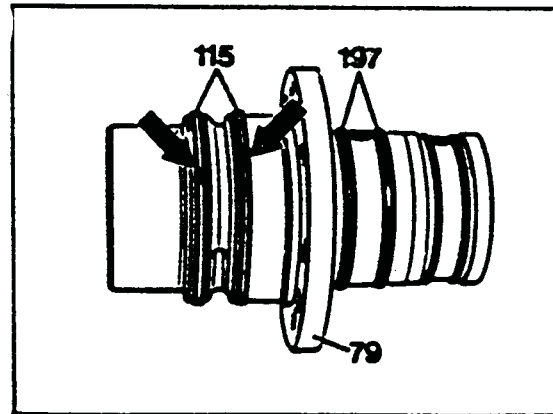



Technical Service Information

47-Insert support flange (79) with hole pattern corresponding to mounting holes, use two approx. 80mm long bolts to center.

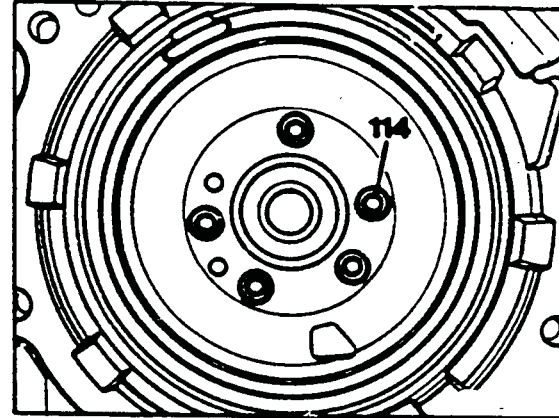

48-Install allen screws (114) M6x16 and tighten to 11 Nm.

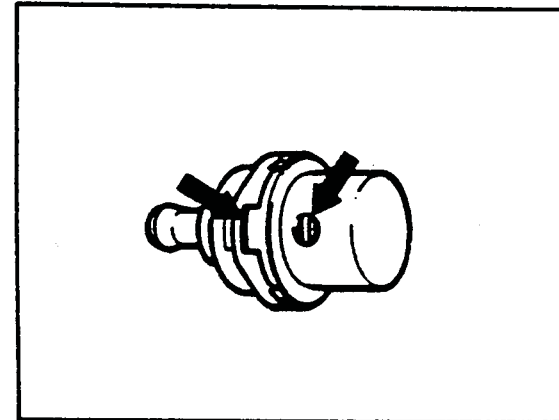

49-Assure that thrust element B2 is not twisted. When the thrust element is removed the hole should point in the same direction as the tab (arrows).

When the thrust element is installed one spring coil of the thrust element should be visible through the hole in the oil tube on the lower cover.

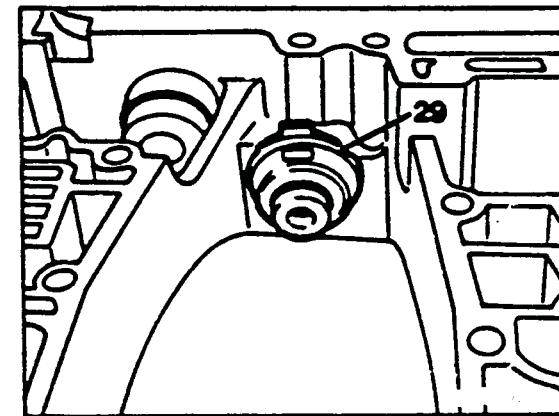

50-Insert thrust element B2 (29) with tab (arrow) pointing up.



Technical Service Information

51-Insert thrust washer (113) so that tab to prevent rotation (arrow) is set in housing.

NOTE:

Check seat of teflon rings on support flange (79) again.

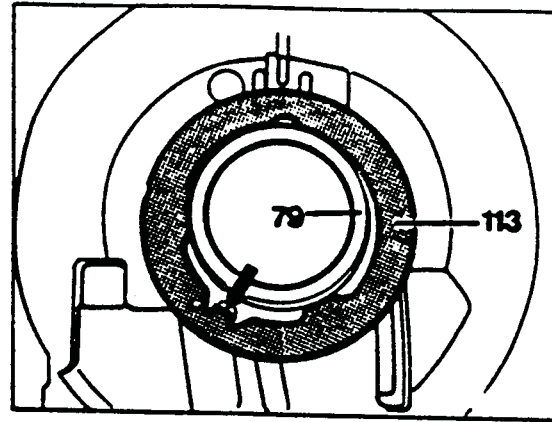

52-Press brake band B2 (27) together on support tabs as far as possible and insert into housing.

To facilitate assembly the brake band can be held together with a clamp (23) or a clip.

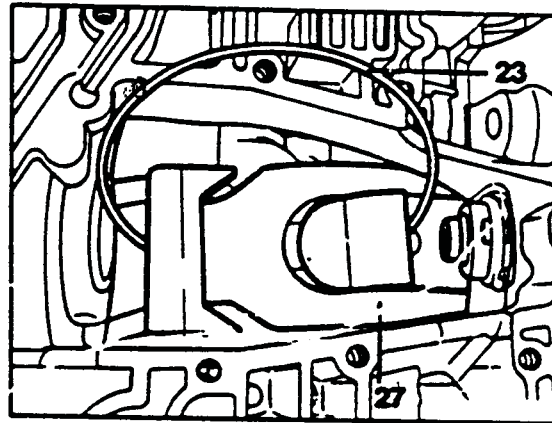

53-Grease grooves in intermediate shaft (167). Insert teflon rings (167a) and press into groove until gap is closed.

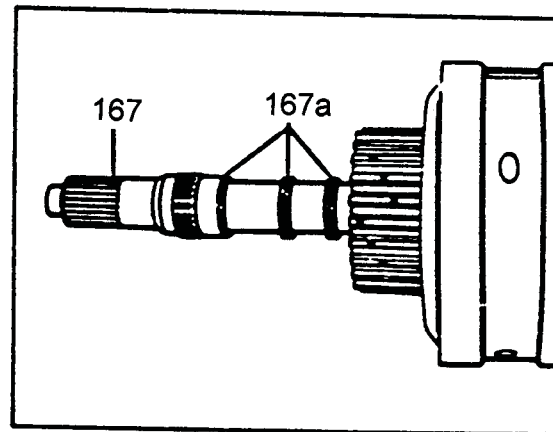

54-Install clutch K2 (100) on planetary gear set.

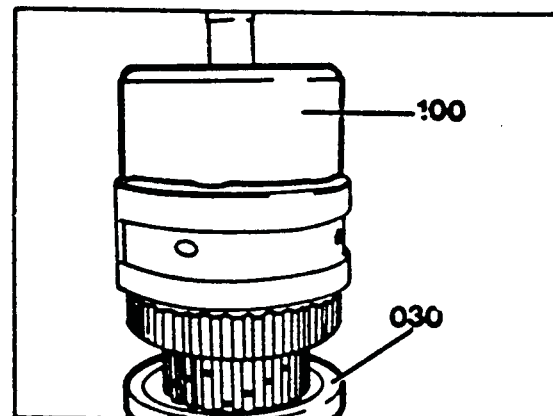



Technical Service Information

55-Insert planetary gear set into transmission housing while turning input shaft (87).

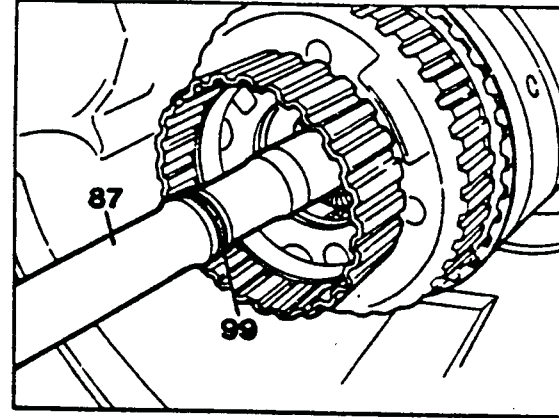

56-Place transmission in vertical position with input shaft (87) pointing upward.

57-Check installed position of planetary gear set. The planetary gear set is installed properly when the upper edge of the front connection support (arrow) is lower than the support surface (138) of the outer disc LE3.

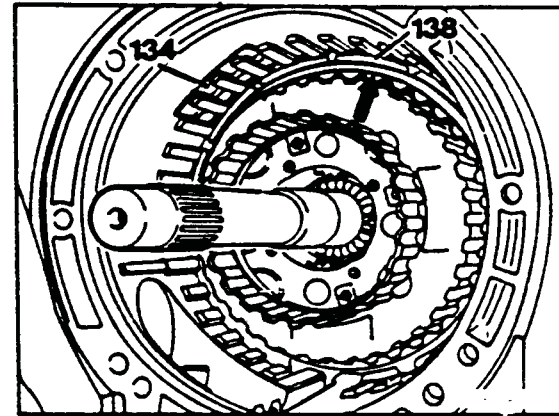

58-Reassemble front cover with the front pump Install damping spring (134).

59-Position plates for clutch pack brake B3 in sequence as shown in figure and insert individually..

- 133b inner plate
- 133a outer plate
- 85 Plate spring
- 10 Piston LB3

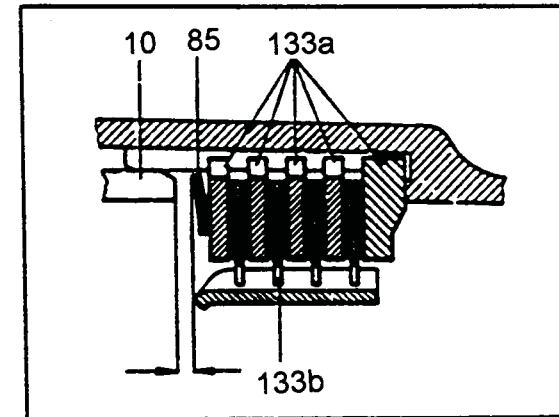

60-Measure release clearance "L" of multiple plate brake B3 and adjust.

Measure dimension "a"

Position parallel support (029) on machined surface and measure the distance to outer edge of plate spring (85)

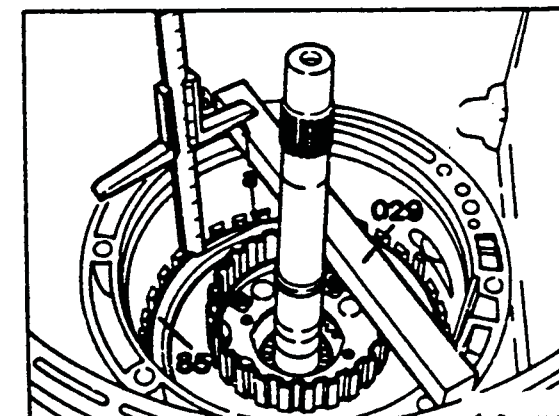



Technical Service Information

Measure dimension "b"

Position parallel support (029) on piston for multiple disc brake (arrows and measure depth of gasket (11). The difference between these two values is equal to the release clearance "L". Set release clearance "L" to nominal value of 1.5-2.0mm. Compensate by using outer plates available in different thickness .

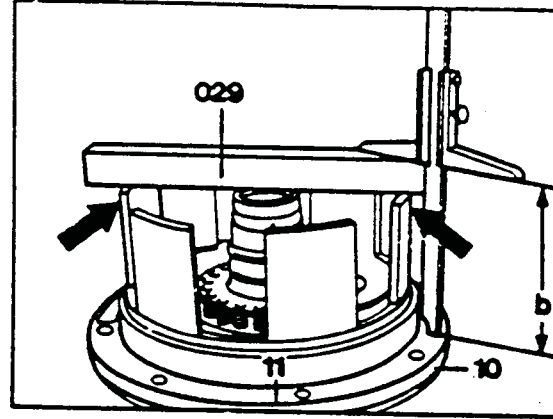

61-Grease groove in drive shaft (87). Insert lubricating pressure ring (99) and press into groove until gap is closed.

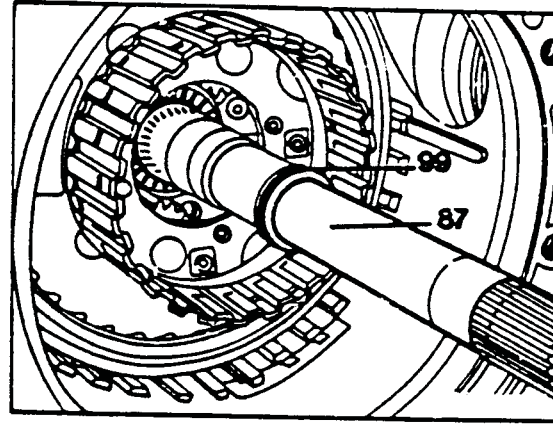

62-Hook assembly lock (arrow) on brake band B1 (30).

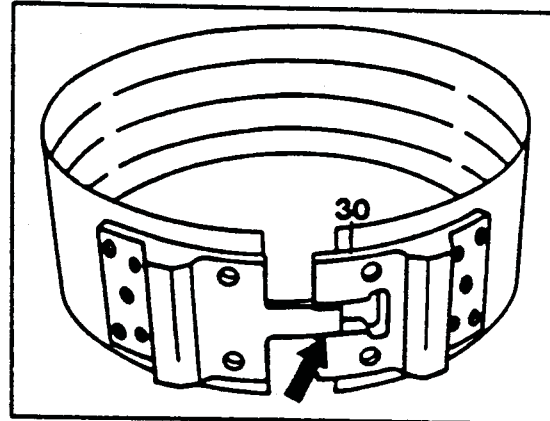

63-Insert clutch K1 (83) while turning so that teeth mesh.

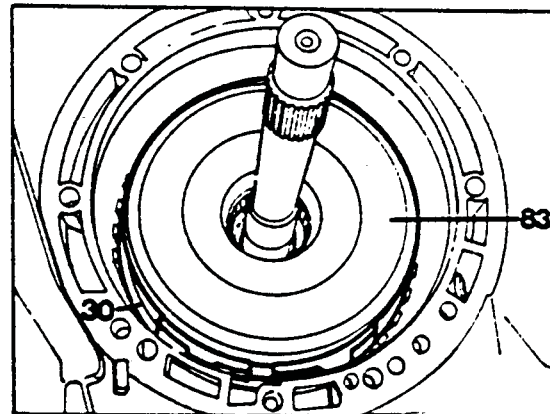

64-Insert brake band B1 (30) so that pin of assembly lock (arrow, figure item 62) points toward thrust element B1.



Technical Service Information

65-Replace O-rings. Then insert thrust element B1 (31) with thrust pin, screw in overload protection switch (S65) and tighten to 70 Nm.

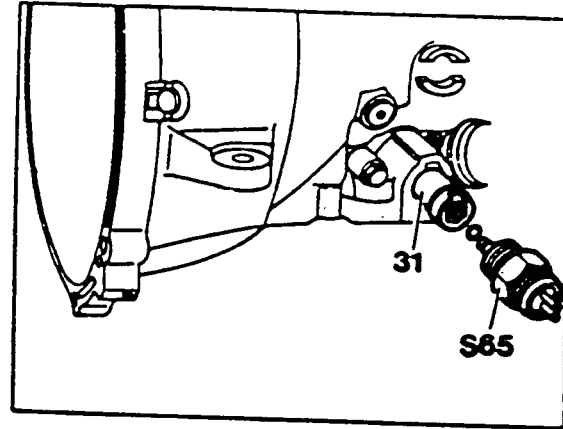

66-Insert brake band guide (34). Assure that the locating pin engages in the hole in the housing: press in until it can be felt engaging.

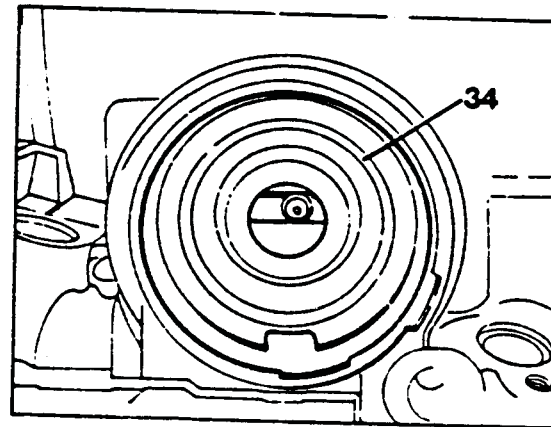

67-Measure end-play "B" for K1 Clutch and adjust.

Rear housing not installed 0.8-1.2mm
Rear housing installed 0.4-0.6mm.

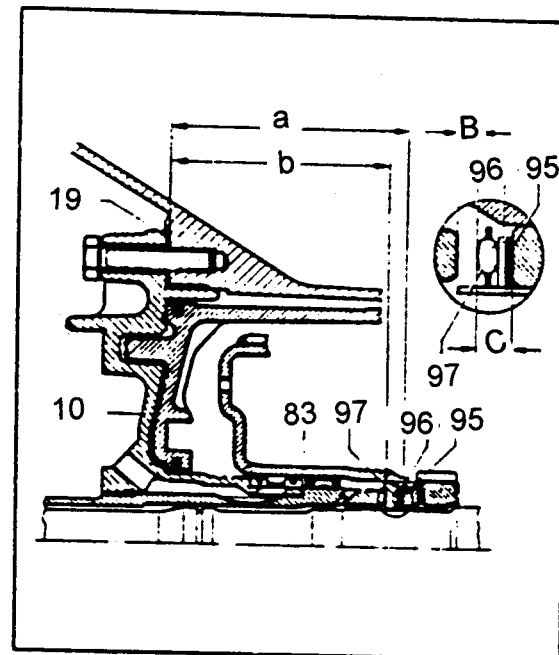

- 95 Shims
- 96 Thrust washer
- 97 Thrust bearing



Technical Service Information

Place gasket (19) on front cover (10).

Position parallel support (029) (Mercedes tool 126 589 04 31 00) on flange (arrow)

Measure distance from parallel support to gasket (11) with depth gauge (dimension "b").

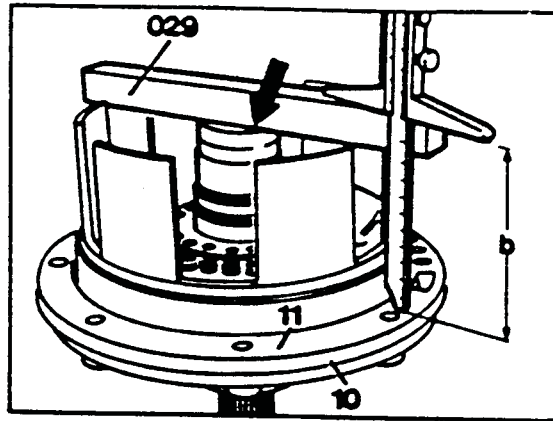

Position parallel support (029) on machined surface of transmission housing. Measure distance between parallel support to contact surface in clutch K1 (83) with depth gauge (dimension "a").

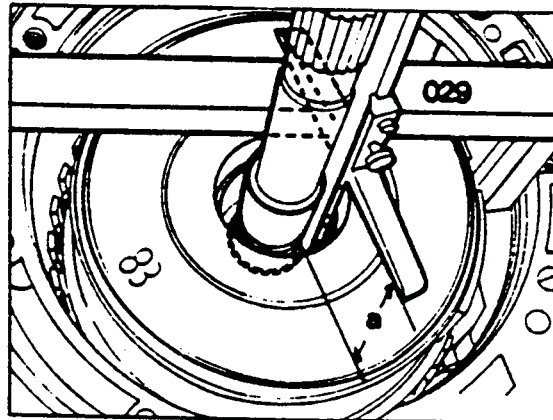

Hold shim (95), thrust washer (96) and thrust bearing (97) together and measure dimension "c" with vernier calipers. The end play "B" for clutch K1 is equal to dimension "a" minus dimensions "b" and "c" ($B=a-b-c$). The end play can be adjusted by inserting appropriate shims (95) (thickness 0.1;0.2;0.5mm)

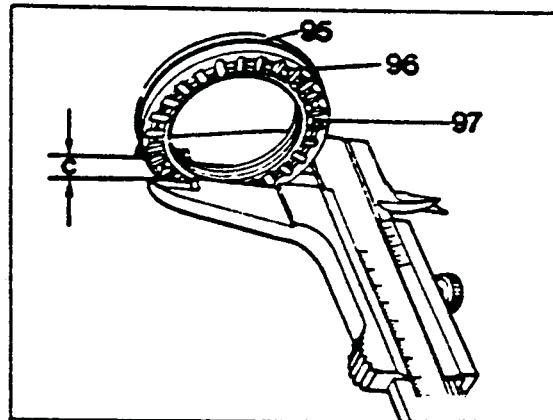

68-Insert measured shims, thrust washer and thrust bearing into K1 one after the other.



Technical Service Information

69-Install teflon rings (9) with grease. Assure that the ring gap (arrow) remains closed. If required remove rings and reform to smaller diameter.

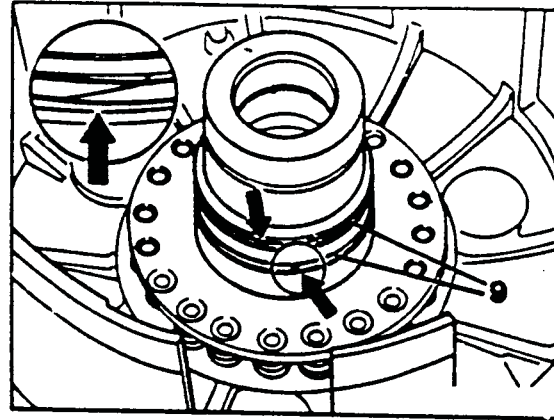

70-Insert front cover (10) with gasket, tighten bolts (18) M8x40 to 13 Nm.

NOTE:

The gasket can be used a number of times, however it must nOT be coated with sealant. The bolts should be coated lightly with a non-hardening sealant.

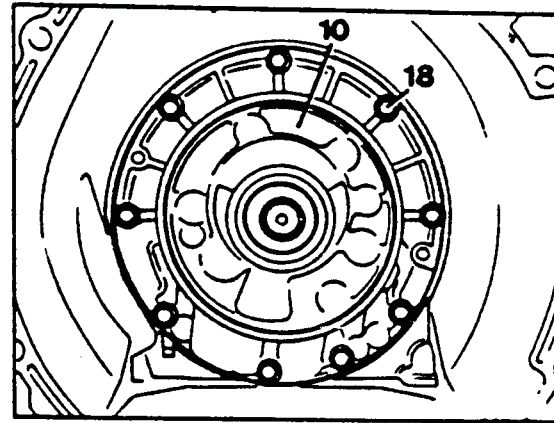

71-Insert catch plate (82) with resilient linkage and push in shaft (76).

72-Install allen screws (82a) and tighten to 8 Nm.

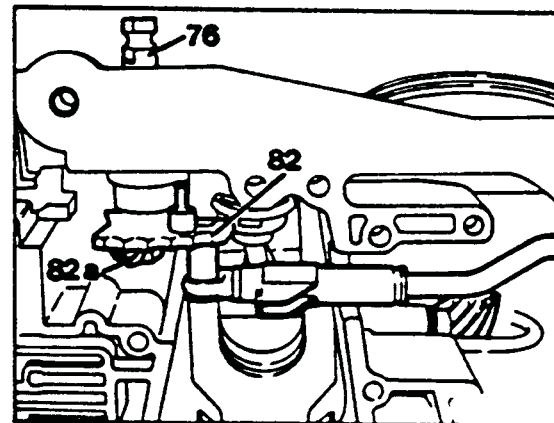

Technical Service Information

73-Install roller (81) on resilient linkage. Attach plastic guide (80) and press into locating holes.

74-Attach parking position pawl (74), install spreading spring (75) and hook onto parking position pawl (74).

75-Clip 9-pole round plug (Y3/1x1) into housing together with cable.

76-Install brake, high gear (BS) and measure.

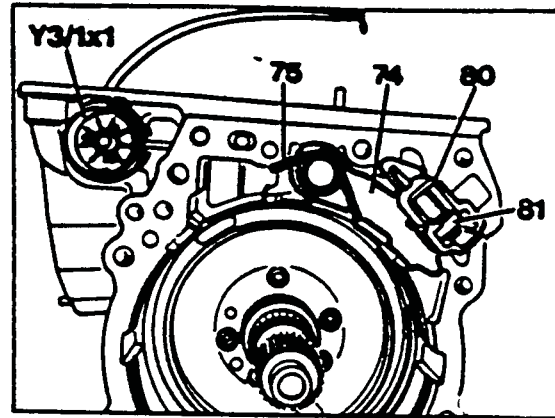

77-Insert modulator pressure control valve (59) and thrust pin (59a).

78-Attach vacuum control unit (60) with retaining plate (57), tighten allen screws (58) M6x15 to 8 Nm.

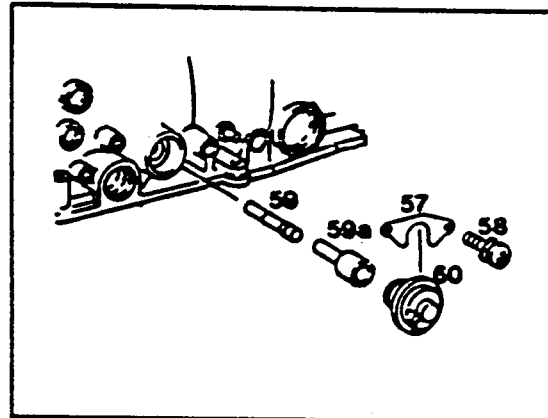

79-Position starter lock-out switch (53), screw in mounting screws (55) M6x18, however at this time donot tighten.

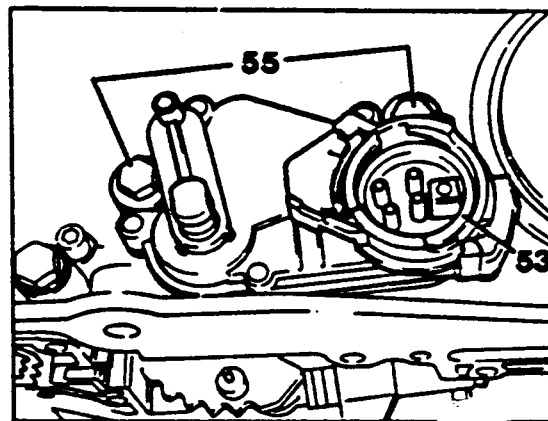



Technical Service Information

80-Install lip seal (39) on brake Band piston B1 (37) so that sealing lip points outward.

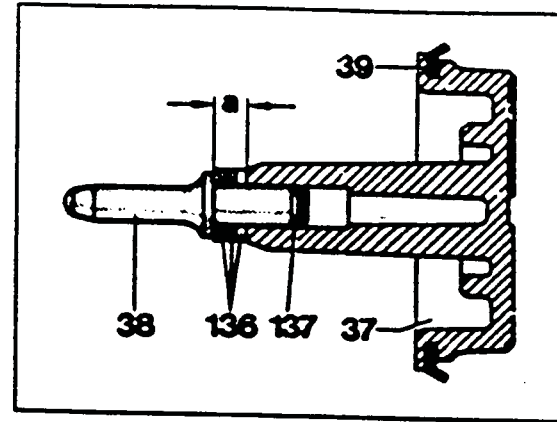

81-Attach servo assembly device onto transmission housing. (Mercedes tool number 125 589 06 21 00.)

82-Insert brake band piston B1 (37) with new pressure spring and measuring device (031). (Mercedes tool number 125 589 06 21 00).

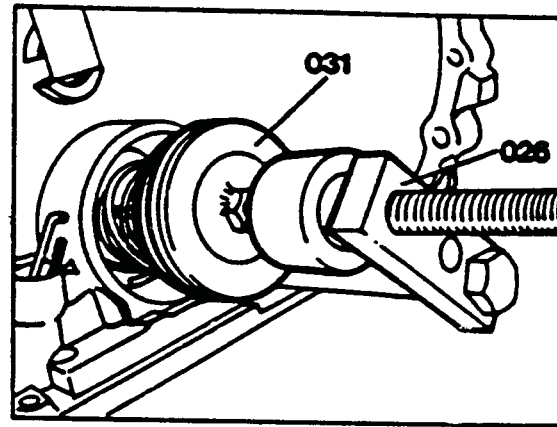

83-Screw assembly device spindle (026) in assuring that the thrust pin on brake band piston B1 (37) slides into brake band and lip seal (39) is not damaged.

NOTE;

To adjust release clearance it is sufficient to install one pressure spring.

84-Install retaining ring (41), release assembly device (026) and remove.

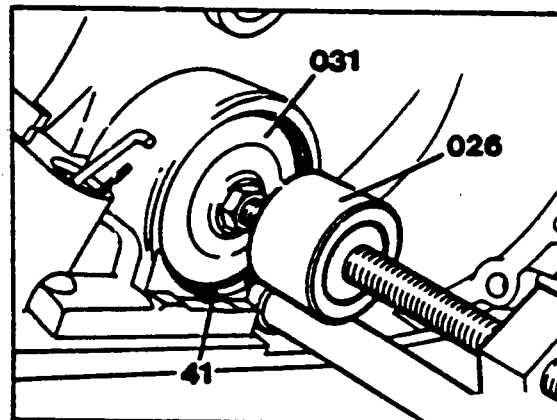

NOTE:

To remove and install the retaining ring (41) without screwing out the plug (33) or transmission overload protection switch (33b), machine a bevel (arrow) on first version measuring devices.

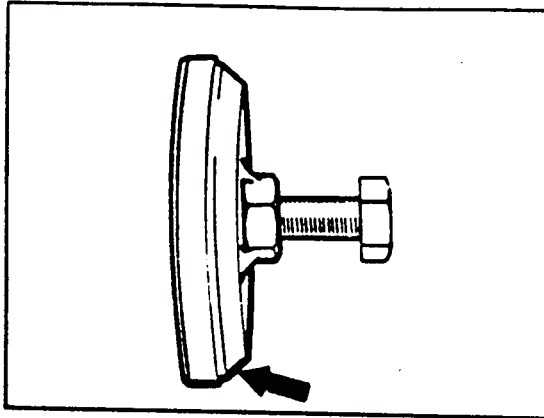

85-Measure and adjust release clearance "L" on brake band B1.

NOTE:

The thread on the measuring device (031) has a 1mm pitch so that one turn is equal to a distance of 1mm.

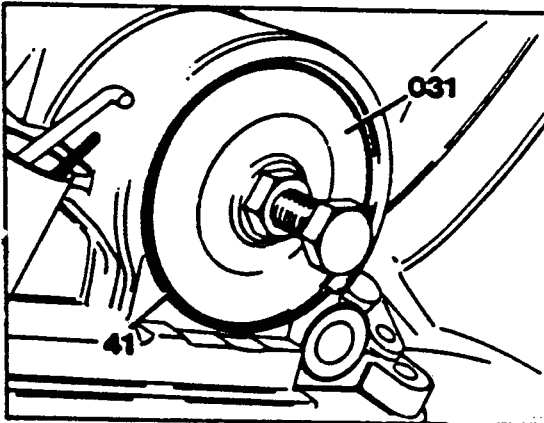

Screw in bolt on measuring device (031) by hand until resistance is felt.

Continue to screw in bolt with torque wrench while counting rotations and tighten bolt to 1 Nm.

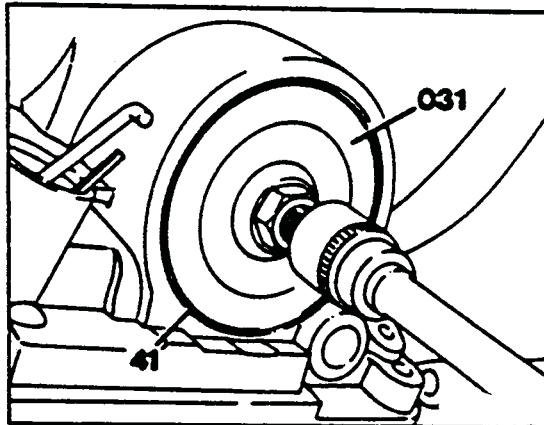

The idle path for the brake band should be 1.8-2.5mm, which means that a torque of 1 Nm should be reached after 1.8-2.5 rotations.

The release clearance can be adjusted by inserting or removing shims (136) behind the thrust pin (38).

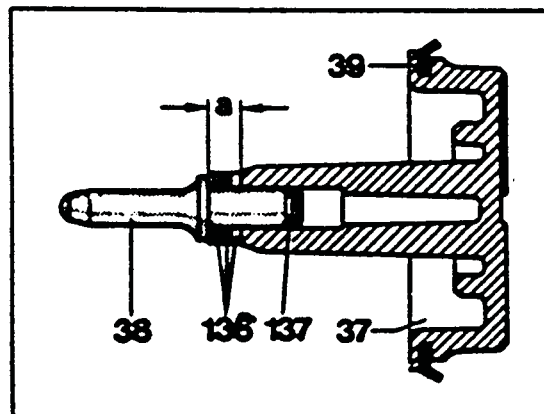



Technical Service Information

86-Reattach assembly device (026) and screw on. Install brake band piston cover (40) and second pressure spring in place of measuring device (031) and then remove assembly device (026).

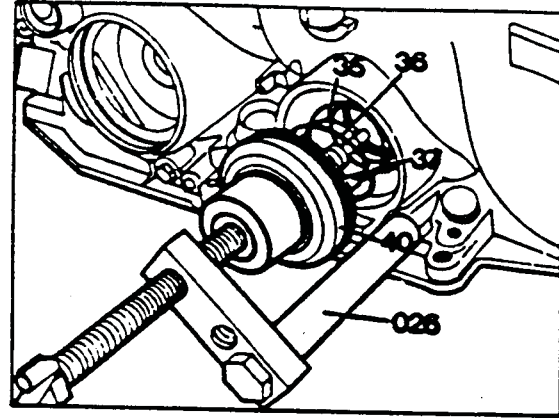

87-Insert thrust pin counter bearing B2 (28) with larger diameter toward brake band B2 (27).

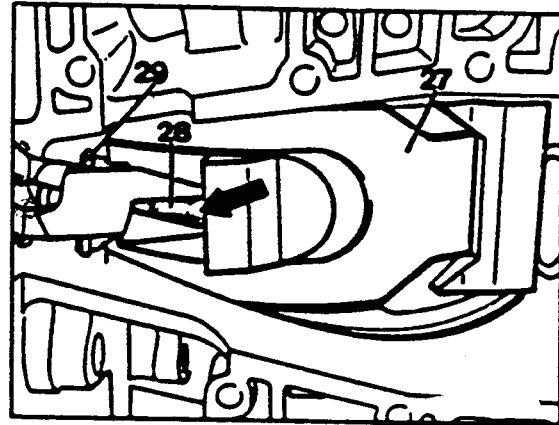

88-Insert teflon ring (25) into groove with grease.

89-Insert thrust pin (26).

NOTE:

Thrust pins (26) are available with lengths of 47.2; 48.8 and 49.6 mm for compensation of the idle travel at brake band B2.

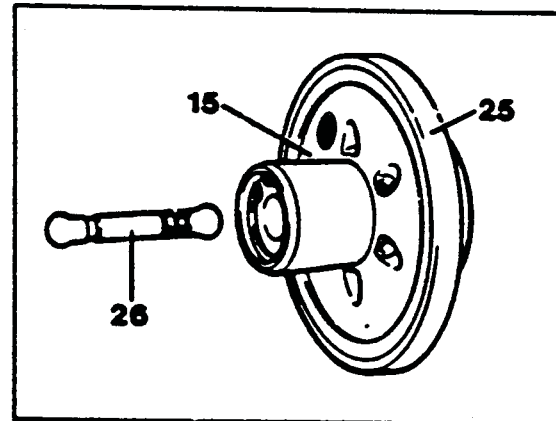

90-Insert brake band piston B2 (15), while assuring that thrust pin (26) engages in brake band.

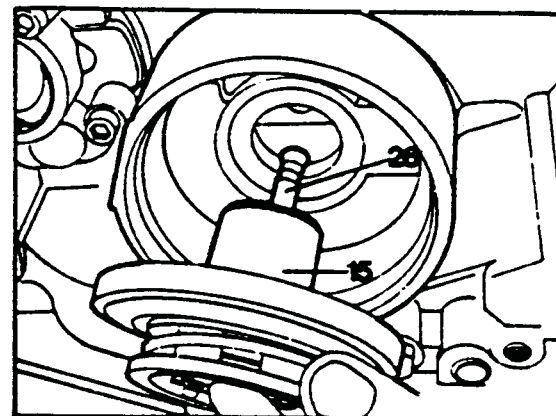



91-Press in brake band piston cover B2 (17) and install retaining ring (23).

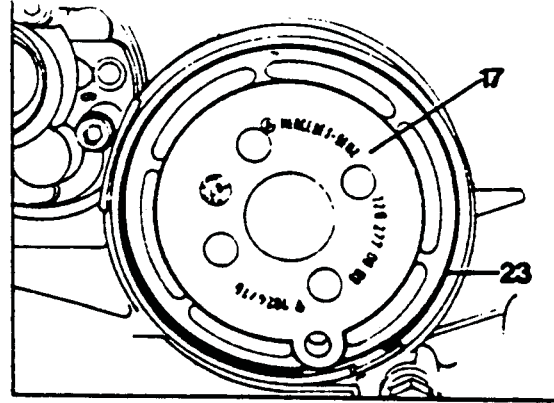

92-Measure release clearance "L" on brake band B2 and adjust.

Press brake band B2 (27) toward brake band piston (direction of arrow) on support tab so that brake band piston is against brake band piston cover. Measure dimension "a" on brake band with vernier calipers.

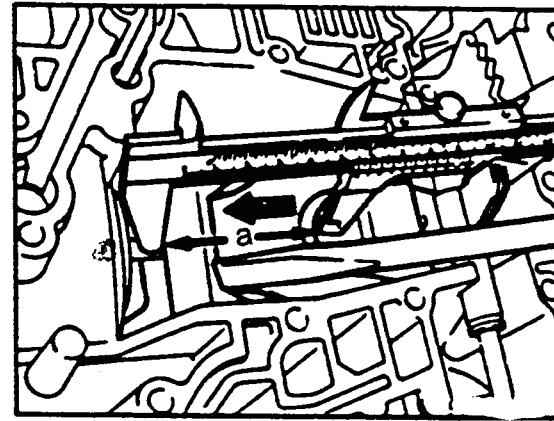

Also press brake band B2 (27) toward thrust element (in direction of arrow) on support tab (27).

Measure dimension "b".

The release clearance "L" is equal to the difference between the values "a" and "b".

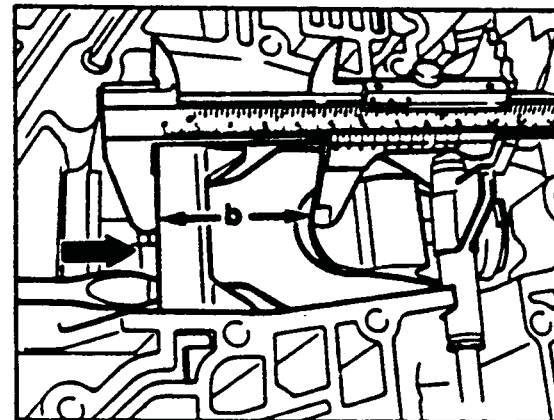

Adjust release clearance "L" to 5.5-6mm by replacing thrust pin (26) on brake band piston B2.



Technical Service Information

93-Install brake band guide pin B2 (101), one-way valves (49), temperature throttle (117) and oil deflector (119) into transmission housing.

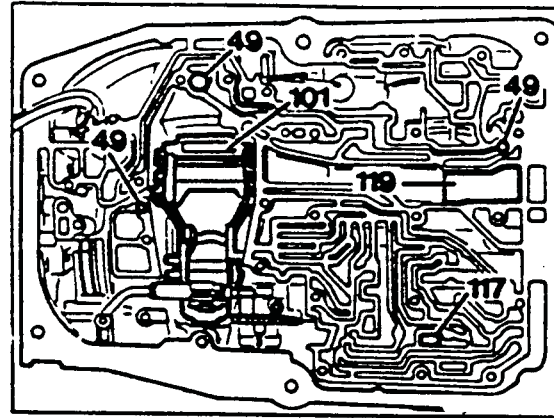

94-Attach lower cover with intermediate plate while assuring that oil tube (9) slides into hole (arrow).

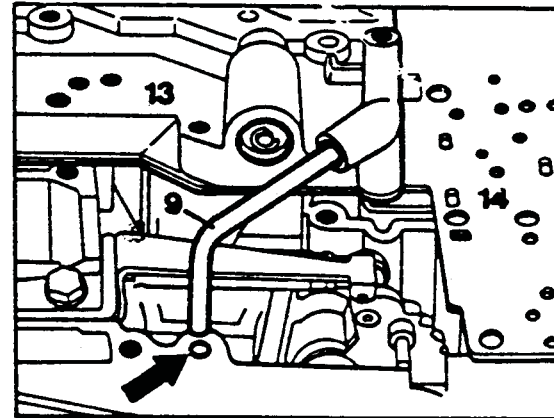

95-Center intermediate plate (14) with two bolts (7).

96-Insert combination screws (8) M6x30 and tighten to 8 Nm.

97-Attach leaf spring (142) with holder (141) tighten screw (140) M6x18 to 8 Nm.

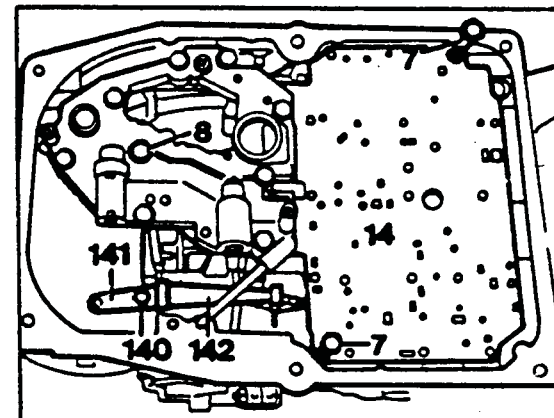

NOTE:

Assure that the locating pin for the holder (141) is correctly inserted.



Technical Service Information

98-Attach shift valve housing (A) while assuring that the range selector valve (A1) engages in the driver on the catch plate (arrow).

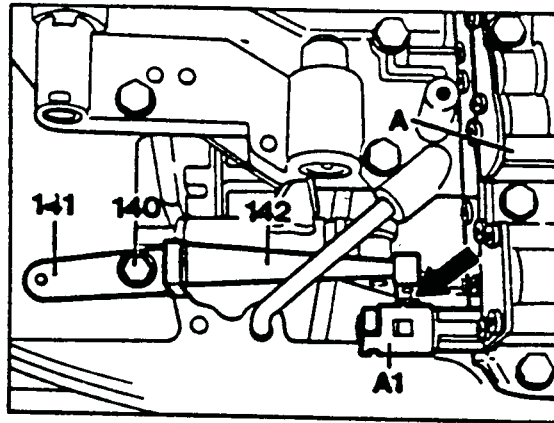

99-Insert combination screws (7) and tighten to 8 Nm.

CAUTION:

Observe length of screws. The three screws marked with a number 7a are only 50 mm long, the other 12 screws are 55 mm long.

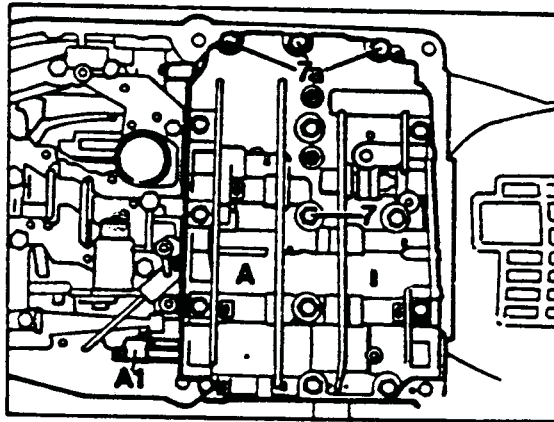

100-Check play "a" between locking piston (122) and stop on resilient linkage (82), adjust if required.

The play "a" can be adjusted to 0.4-1.0mm in position :N: using plastic clips (118). The plastic clips are available in two thicknesses.

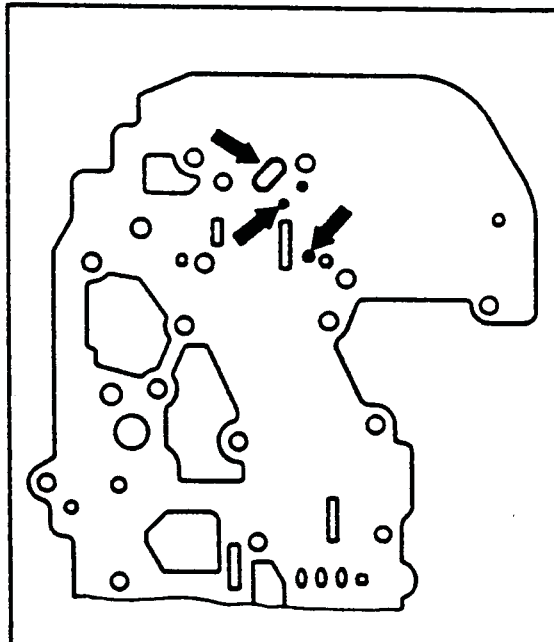



Technical Service Information

101-Properly lay cable from 9-pole round plug and connect with terminal screws (139).

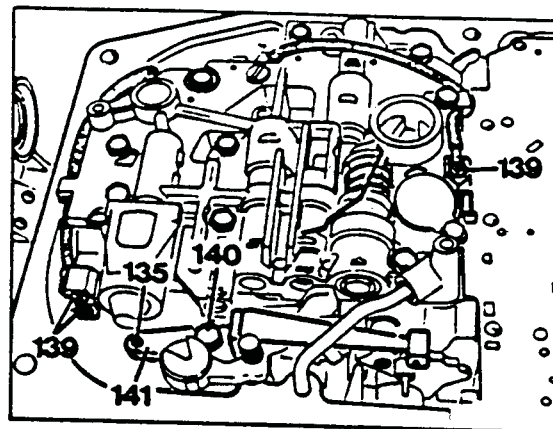

102-Hook connecting rod (150) into adjustment and retaining plate (151).

103-Adjust play "X" = 0 to 0.5 mm between locking lever (152) and catch plate (82) with adjustment and retaining plate.

104-Assure that catch plate can be switched to catch positions (P R N 4 3 2).

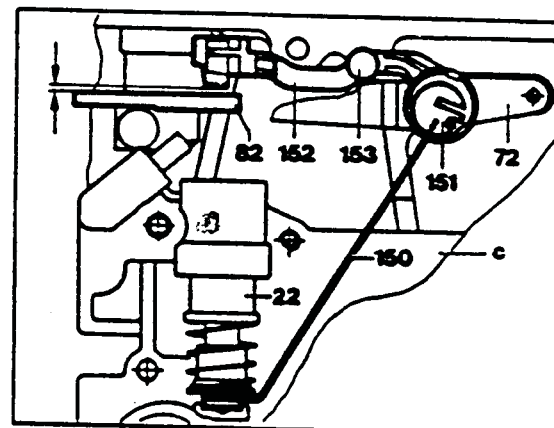

105-Install range selector lever (52) so that driver (54) is engaged in range selector lever.

106-Insert hex head bolt (51) and tighten to 8 Nm.

107-Move range selector lever (52) to position "N", insert a 4mm pin (arrow) through the range selector lever into the locating hole on the switch housing and tighten mounting screws (55) to 8 Nm. Remove pin.

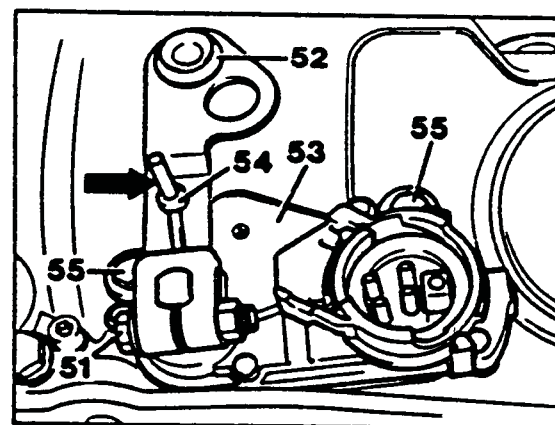

108-On vehicles with catalytic converter screw on switch over valve for increasing shift point (Y3/2) together with oil line.

INSTALLATION NOTE:

First tighten pressure oil line (MR), then oil lin (O) and holder for switch-over valve (Y3/2).

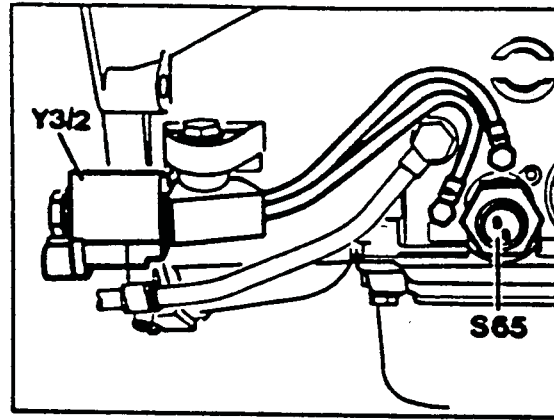

109-Check O-ring on control pressure cable, replace if required. Then hook control pressure cable onto connecting rod (110). Insert limitation rod (111) into hole (arrow) and attach control pressure cable.

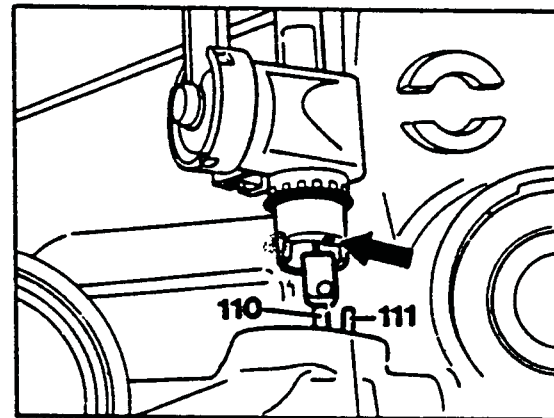

110-Turn control pressure cable until lock catches.

111-Attach oil filter, tighten phillips screws to 4 Nm.

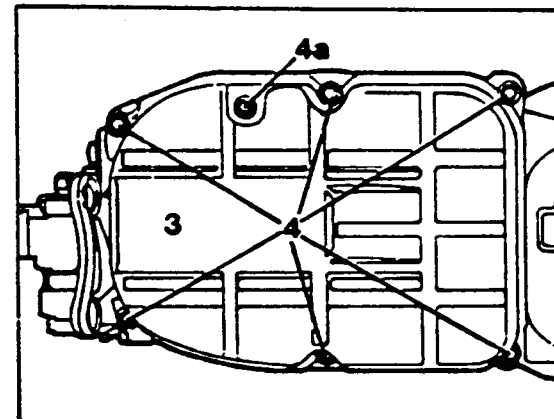

112-Attach oil pan (3), tighten mounting bolts (4) to 8 Nm.

113-Remove bolt (arrow) and lift transmission from bench holding fixture.

After installing transmission check for leaks also check modulator pressure and adjust if necessary.

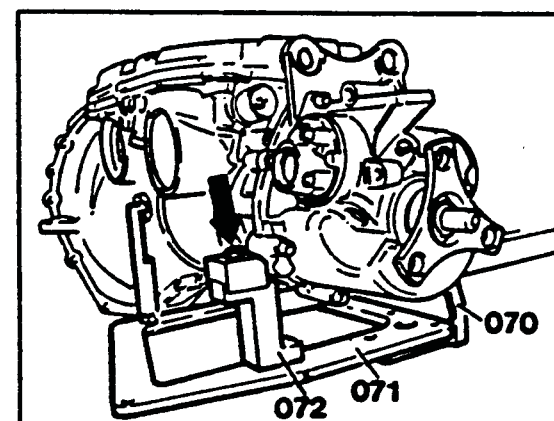



Technical Service Information

COMPONENT ASSEMBLY

NOTE:

Apply oil to bearing points and friction surfaces during assembly.

DISASSEMBLY and ASSEMBLY:

1-Remove lubrication thrust ring (99) from input shaft (87).

NOTE:

Insert lubrication thrust ring into groove with grease so that gap is closed.

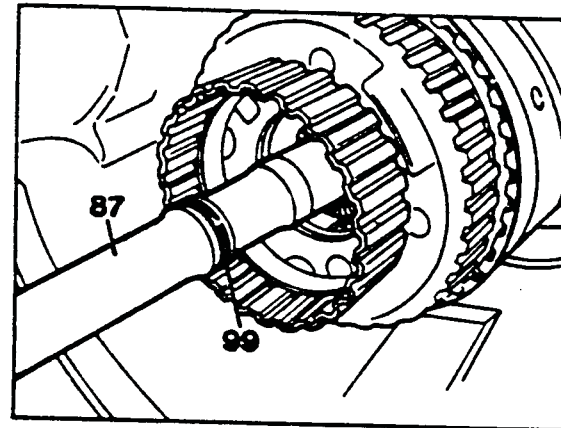

2-Remove teflon rings (167a) from intermediate shaft (167).

Installation note:

Insert teflon rings into grooves with grease so that gap is closed.

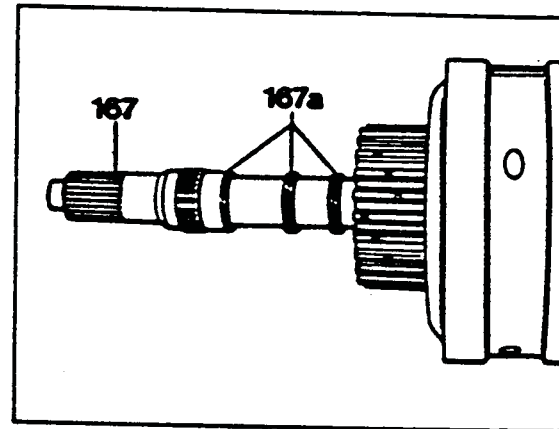

3-Clamp assembly (Mercedes tool 126 589 00 35 00) in vise the two flats with the plate pointing upward. Insert gear assembly into assembly jig with intermediate shaft forward.

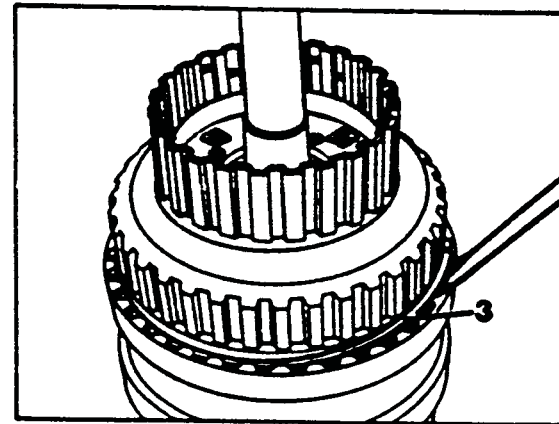

4-Remove retaining pin (3).

Installation note:

After inserting retaining ring, press into groove with screwdriver after attaching front gear assembly.

5-Lift front planetary gear assembly (2) up.

6-Remove thrust bearing (23) from planetary gear assembly and check.

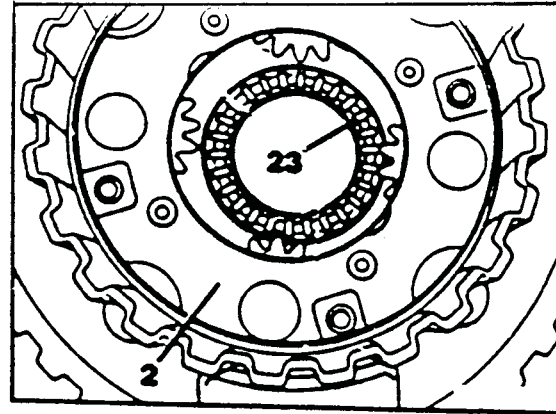

7-Remove thrust bearing (4) and input shaft (1).

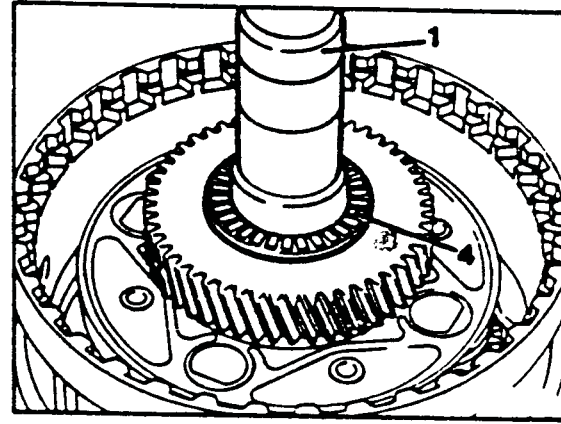

8-Remove radial bearing (5) and thrust bearing (6).

9-Remove intermediate shaft (167).

10-Remove thrust bearing (9) and pull out sun gear (10)

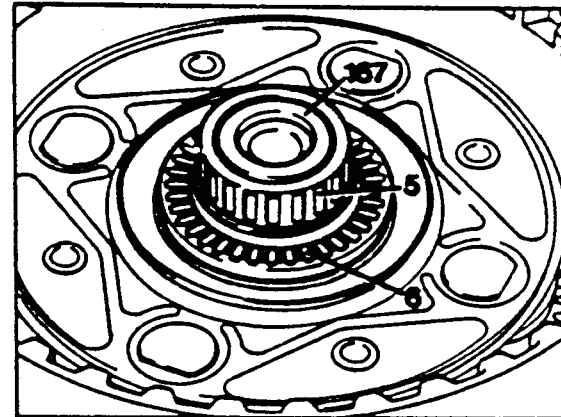

Installation note:

Insert sun gear (10) into one way clutch and turn; the one way clutch should not rotate in the direction of the arrow. The position thrust bearing (9) on sun gear.

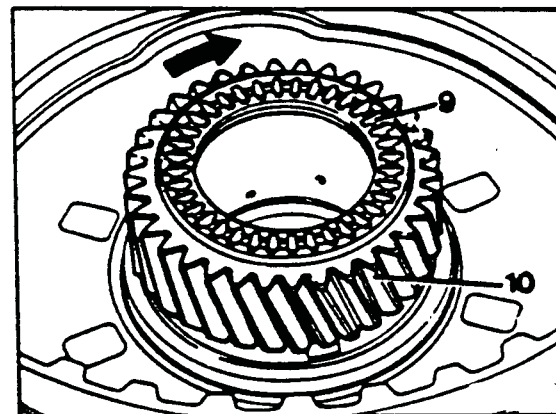



Technical Service Information

11-Turn connecting carrier and remove retaining ring (21).

Installation note:

Press retaining ring into groove with screw driver.

12-Lift inner plate carrier K2 (19) out of connecting carrier (7) together with one-way clutch.

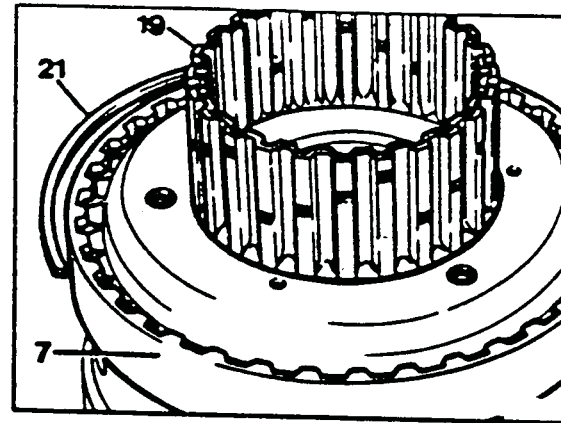

13-Lift supporting disk (11).

Installation note:

Position supporting disk (11) so that the pins engage in the hole in the outer race of the one-way clutch (arrows).

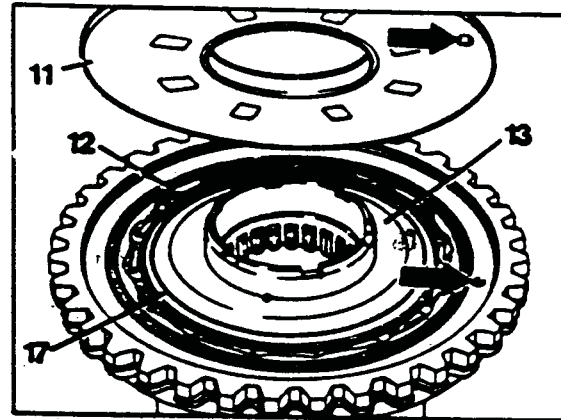

14-Remove shim (17) and O-ring (12).

Note:

Do not disassemble INA brand one-way clutch. If this one way clutch is defective replace.

15-Turn inner race of one way clutch (13) in direction of arrow and pull out while turning.

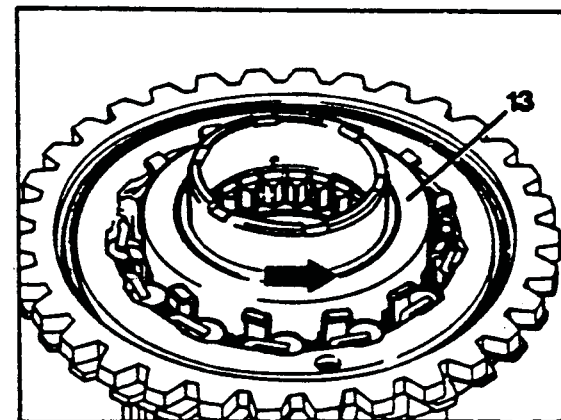



Technical Service Information

Installation note:

16-Press cylindrical rollers (16) against the pressure springs (15) and insert retaining plates (085) with offset pointing towards outside. The retaining plates are available as auxiliary tools. Under part no. 125 277 00 73 (16 each).

Insert inner race of one way roller clutch (13) while turning counter -clockwise, then remove retaining plates (085).



17-Remove cylindrical rollers (16) and roller cage (14) together with pressure springs (15). Check parts for damage.

18-Remove outer ring of one-way clutch (24)

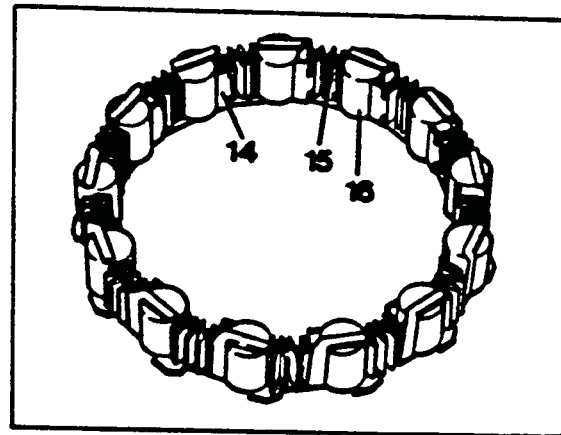

19-Check thrust washer (18) and O-ring (20) for damage and wear.

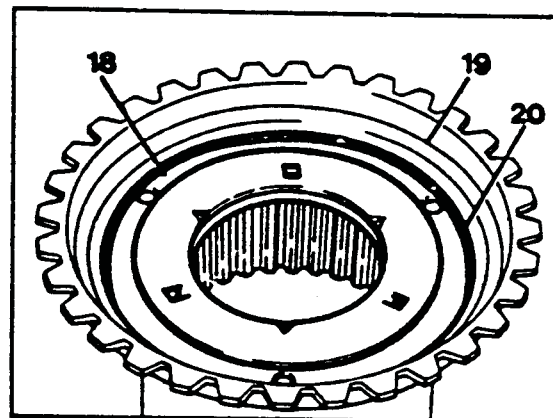



Technical Service Information

20-Check end play of the one way clutch and compensate. Check play between one-way clutch and connecting carrier (7) with feeler gauge.

Note:

When measuring, the O-rings (12,20) should not be installed.

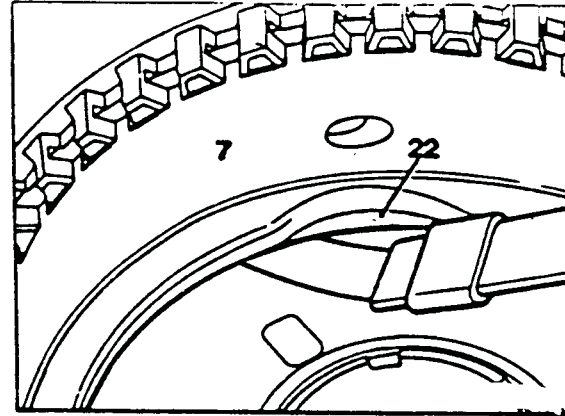

21-Compensate play to 0.05-0.2 mm with shim (22), then insert O-rings (12) and (20).

22-Position shims (22) in connecting carrier (7).

23-Hold one-way clutch together and insert retaining ring in connecting carrier.

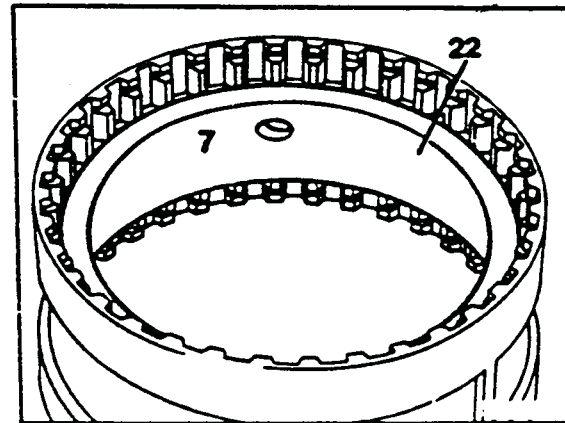

DISASSEMBLY, ASSEMBLY AND MEASUREMENT OF K1 CLUTCH

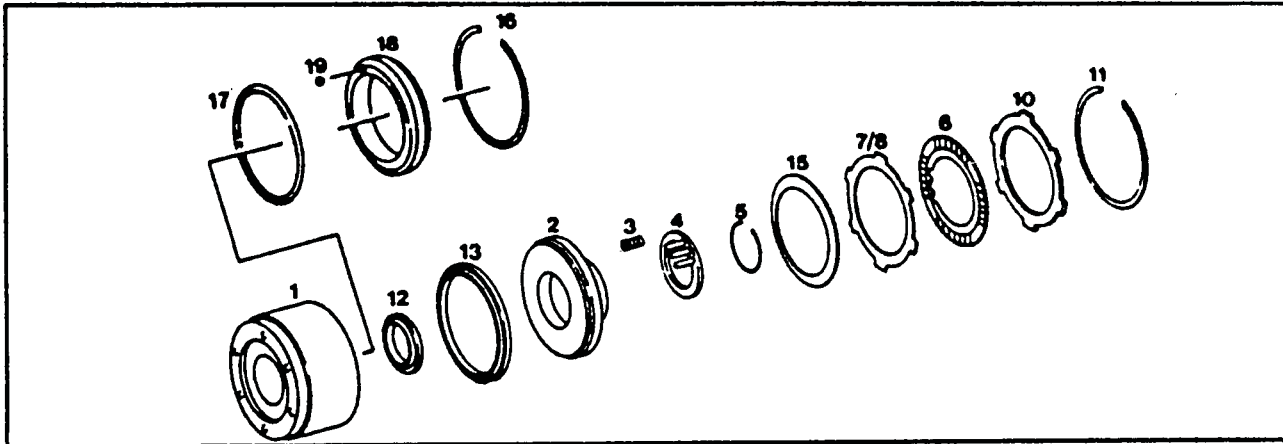

Retaining ring (11).....
Plate assembly (6,7,8 and 10 plate
spring (15).....

remove with screw driver .Install

Remove completely from hub (1). Install. Position in sequence according to transmission type. Position plate spring with crown toward piston .Check and adjust release clearance.

retaining ring (5).....

remove, install. For this purpose compress spring plate until retaining ring is exposed.

Spring plate (4) and pressure
springs (3).....

remove and check number of springs.

piston (2).....

Pull out, To install piston use installation tool.

O-ring (17).....

Test for leakage.

Piston guide ring (18)....

Remove after removing retaining ring.



DISASSEMBLY AND ASSEMBLY OF DRUMS.

1-Remove retaining ring (11).

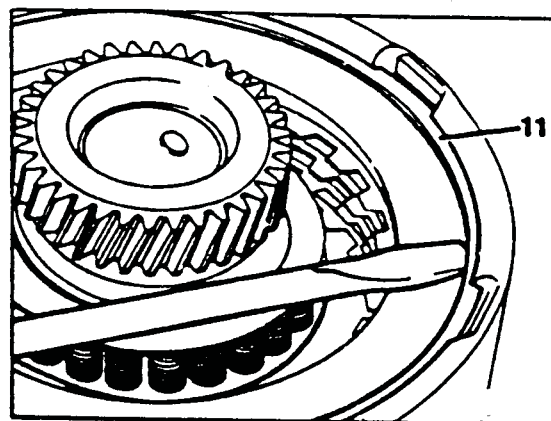

Installation note:

After inserting press up with a screwdriver around entire circumference.

2-Tip outer plate carrier (1) and remove plate assembly. Check inner plates for burned spots and wear (nimal thickness is 2 mm).

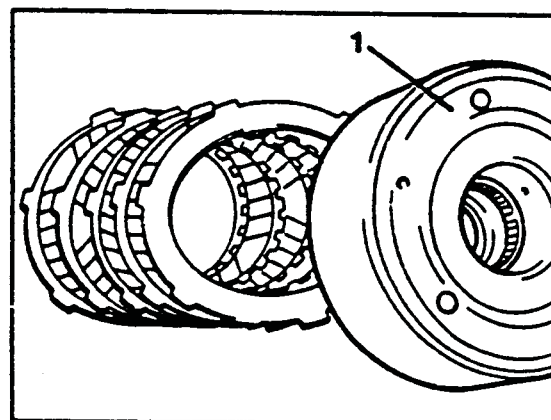

Installation note:

Observe clutch plate sequence. Assemble plate assembly according to transmission type designation and soak in transmission fluid for approximately 1 hour. Position plate and spring toward piston.

3-Set installation device (020) on spring plate (4) and compress unit retaining ring (5) is exposed. Remove retaining ring (5).

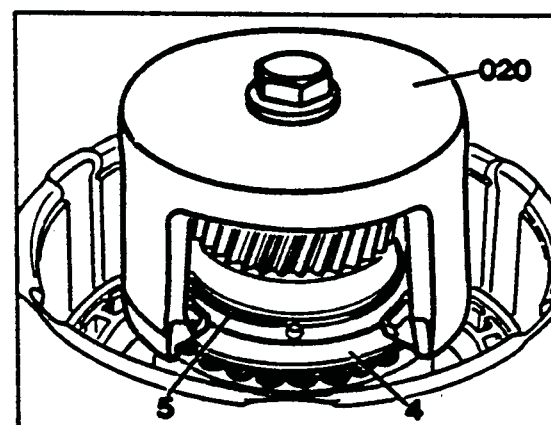

4-Release assembly device and remove. (Mercedes tool number 126 589 00 43 00)

Installation note:

After inserting retaining ring assure that it is seated properly.



Technical Service Information

5-Remove spring plate (4) and pressure springs (3).

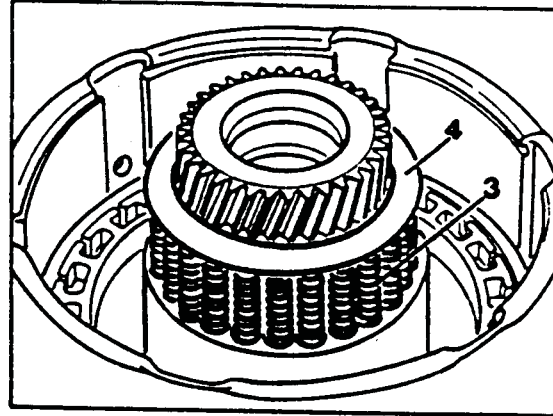

Installation note:

Observe number of pressure springs and assure that each spring is centered on a guide pin on the spring plate.

6-Pull piston (2) out of outer plate carrier (1).

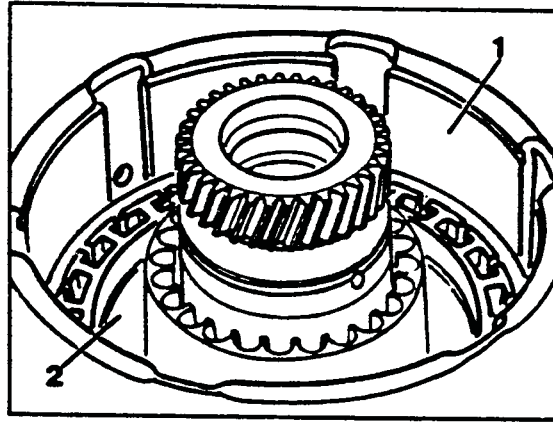

Installation note:

Replace lip seals (12 and 13).

Insert lip seals (12 and 13) into piston (2) so that sealing lip points down (direction of arrows).

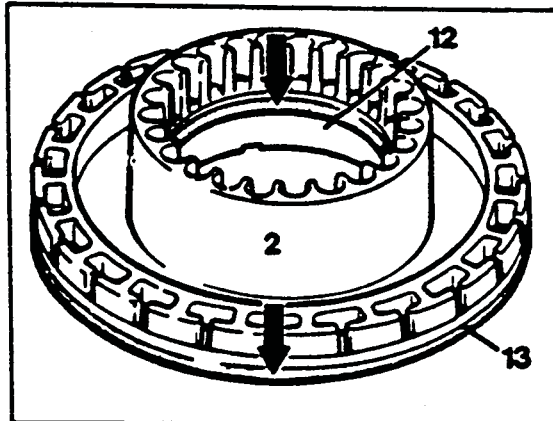

Position insertion sleeve (021) (Mercedes tool 126 589 02 14 00) and (022) (126 589 10 14 00) into outer plate carrier (1),

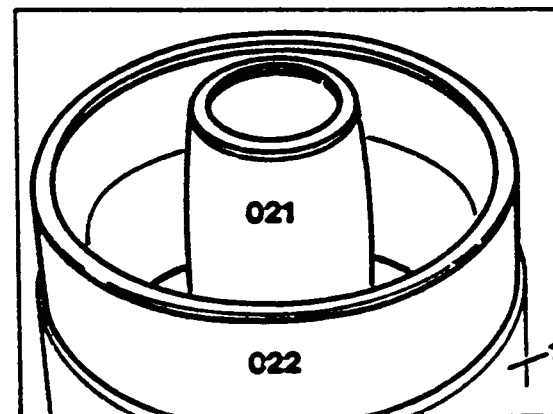



Technical Service Information

7-Coat insertion sleeve and lip seals with transmission fluid and carefully insert piston (2) and press into outer plate carrier (1) without cocking.

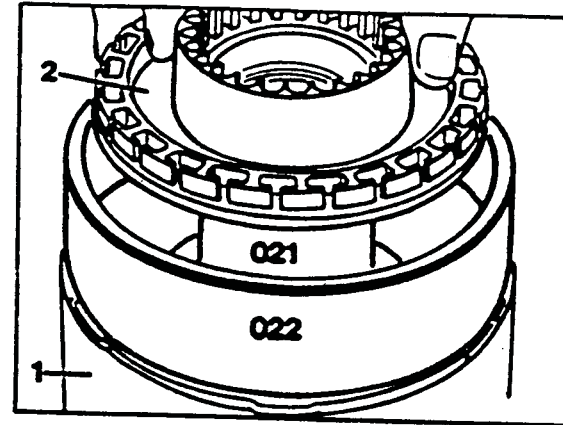

8-Check O-ring (17) between outer plate carrier (1) and piston guide ring (18) for leakage by filling the piston guide ring with a small quantity of kerosene. If the O-ring leaks press out retaining ring (16) remove the piston and replace the lip seal.

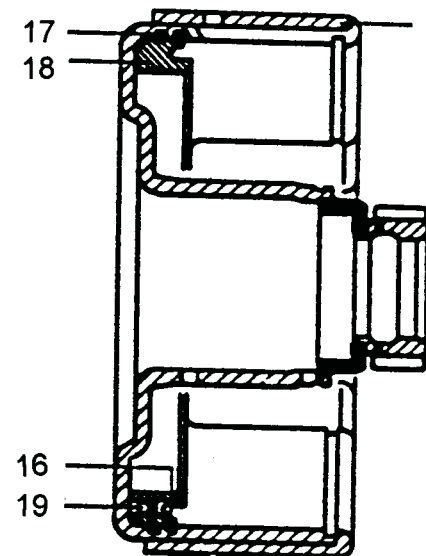

Measurement:

9-Measure play "A" with feeler gauge.

Adjust play "A" with retaining ring (11) available in 3 thicknesses(2.0; 2.5; 3.0 mm). For this purpose machine the groove for the retaining ring to a width of 3.2 mm. If it is not possible to achieve the specified play "A" with the retaining ring (11) alone,additional compensation is possible with the center outer plate. Adjust the release clearance to 0.7-1.3mm.

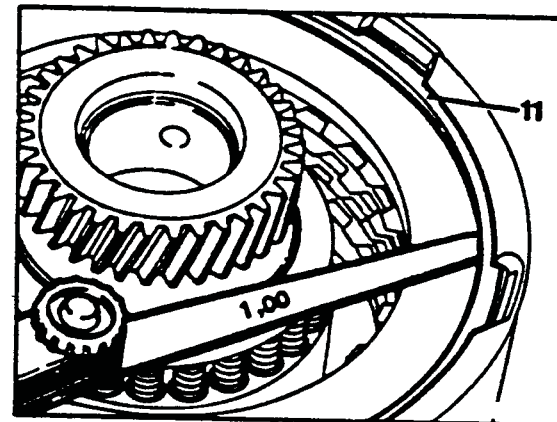



DISASSEMBLY,ASSEMBLY AND MEASUREMENT OF K2 CLUTCH

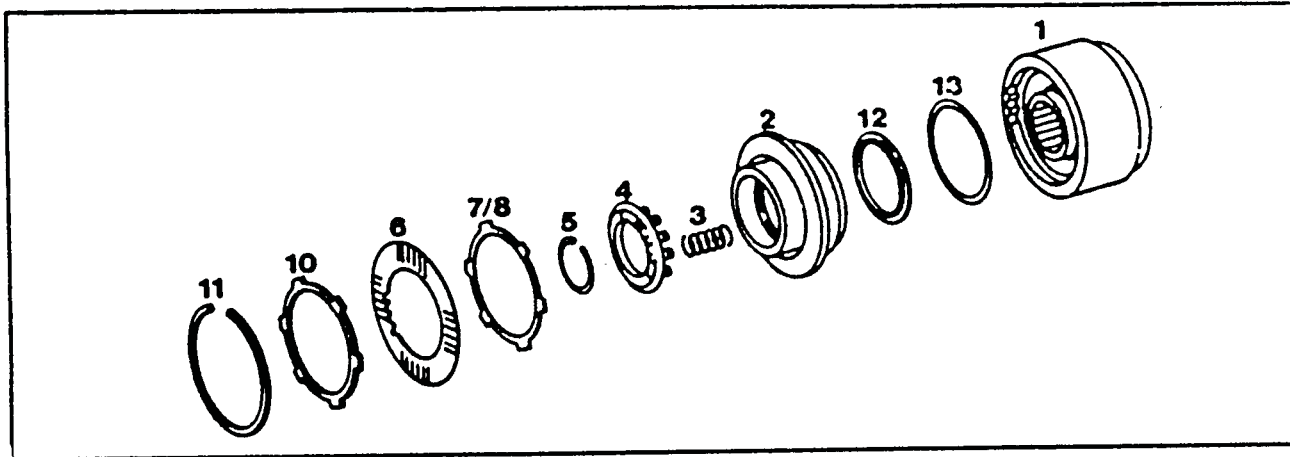

Retaining ring (11).....

remove with screw driver, install

Plate assembly (6,9 and 10).....

remove completely from outer plate carrier(1). Install. Position in sequence according to transmission type. After installation check and adjust clearance.

Retaing ring (5).....

remove,install. For this purpose compress spring plate (4) until retaining ring is exposed.

Spring plate (4) and pressure springs (3).....

remove, spring retainer (4)

Piston (2).....

pull out, To install piston use installation sleeve. Install new seals with lip facing down

O'ring in outer plate carrier (1)....

check for leakage with kerosene.



Technical Service Information

1-Remove retaining ring (11)

Installation note:

After inserting press up with a screw driver around entire circumference.

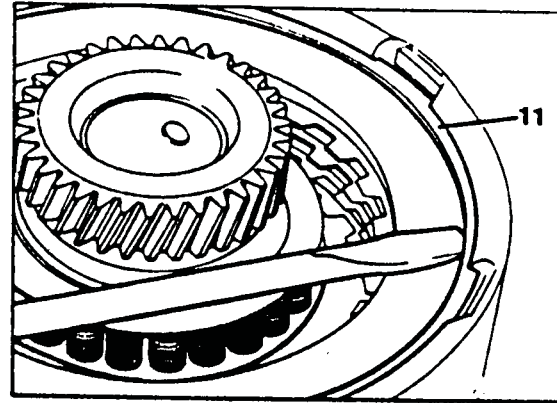

2-Tilt outer plate carrier (1) and remove plate assembly. Check inner plates for burned spots and wear (nominal thickness 2mm).

Installation note:

Observe clutch plate sequence. Assemble plate assembly according to transmission type designation and soak in transmission fluid for approximately 1 hour.

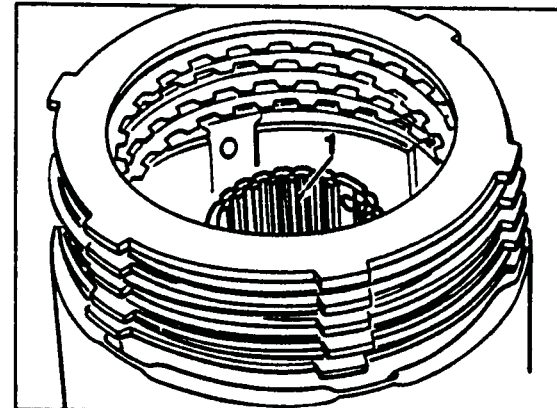

3-Set Installation tool (020) (Mercedes tool 126 589 00 43 00) on spring plate and compress until retaining ring (5) is exposed. Remove retaining ring.

Installation note:

After inserting retaining ring assure that it is seated properly.

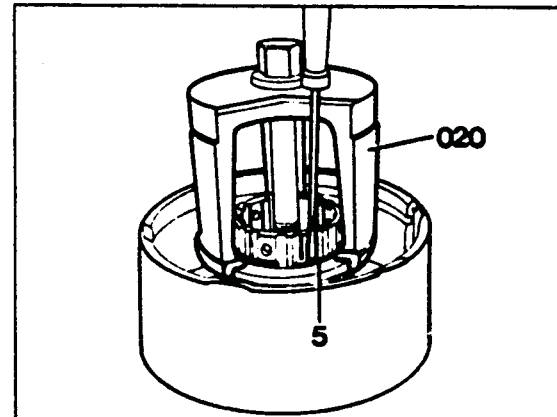

4-Remove spring plate (4) and pressure spring (3)

Installation note:

Observe the number of pressure springs and assure that each spring is centered on a guide pin on the spring plate.

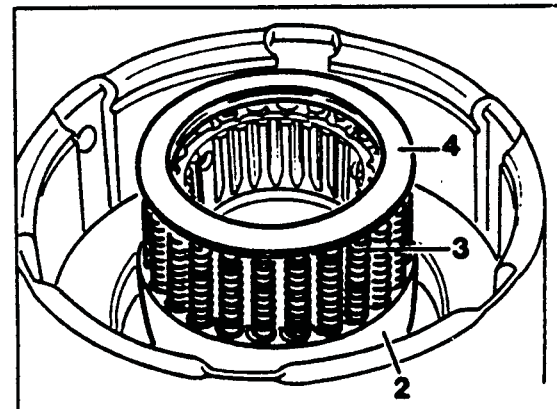



Technical Service Information

5-Pull piston (2) out of outer plate carrier (1).

Note:

Check O-ring between outer plate carrier and piston guide ring for leakage by filling the piston guide ring with a small quantity of kerosene. Then check whether fluid runs out.

If it leaks replace drum.

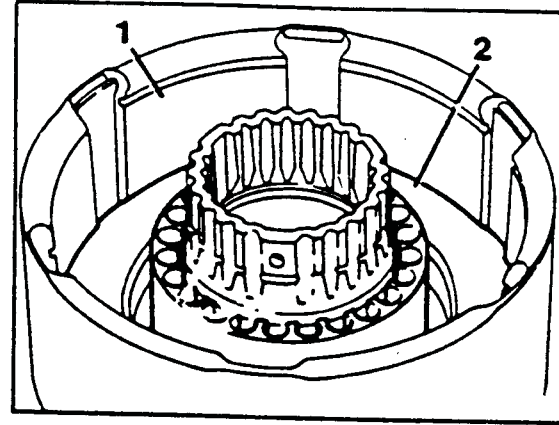

Installation note:

Replace sealing rings (12,13) assure that the rings are not twisted and point in a downward direction (in direction of arrow).

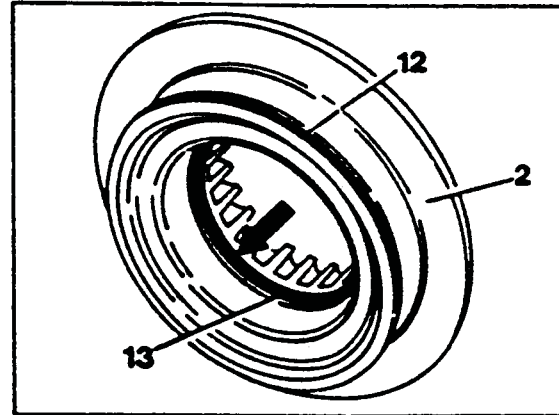

Position installing sleeve (021) (mercedes tool No 126 589 02 14 00) on outer plate carrier (1). Coat sleeve and sealing rings (12,13) with transmission fluid., then carefully install piston into drum. Press piston down while rotating try not to cock piston.

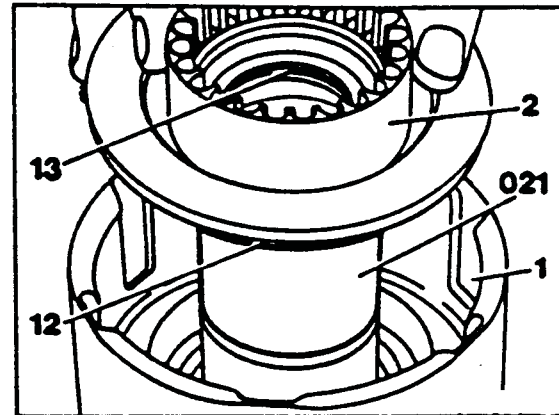

6-Measure play "A" with feeler guage. Adjust the clearance to 0.7-1.3mm.

Note:

Adjust play "A" with retaining ring available in 3 thicknesses (2.0; 2.5; 3.0 mm). For this purpose machine a groove for the retaining ring to a width of 3.2mm. If not possible to achieve the specified play "A" with the retaining ring (11) alone, additional compensation is possible with the center outer plate.

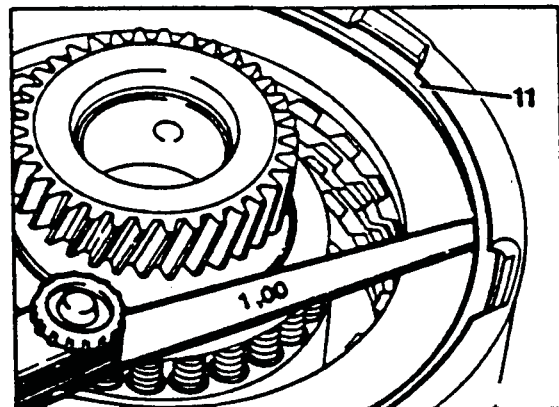



Technical Service Information

Teardown:

1-Engage park position. Screw off double hex collar nut (62) and universal flange (64). (Mercedes tool 126 589 02 09 00).

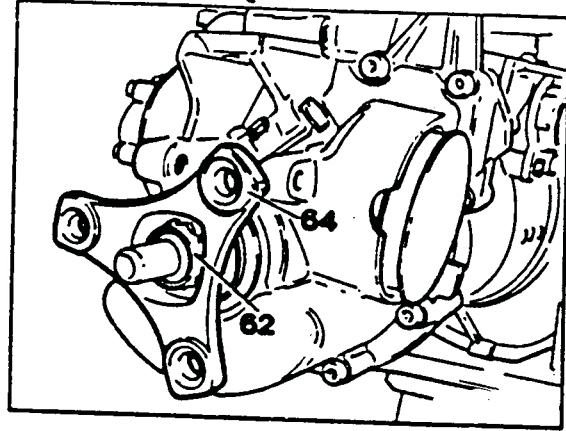

2-Remove washer (65)

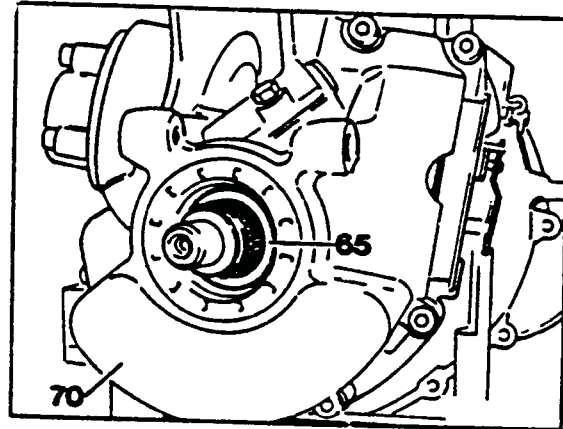

3-Remove allen screws (45) and remove secondary pump(20).

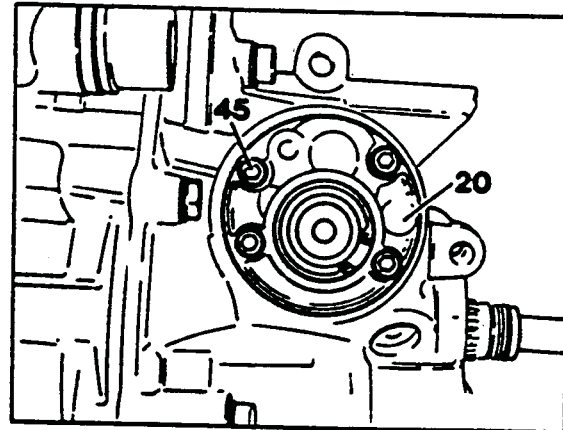

4-Remove O-ring (22) and intermediate plate (21) for rear pump.

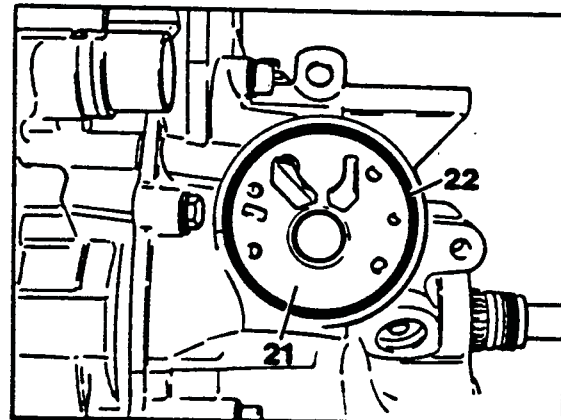



Technical Service Information

5-Press in cover (46) for governor and remove retaining ring (47). Pull out cover (46).

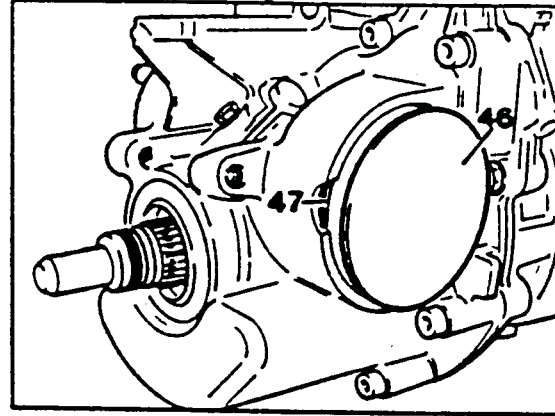

6-Press retaining ring (43) together with a pair of needle nose pliers and pull out governor (50).

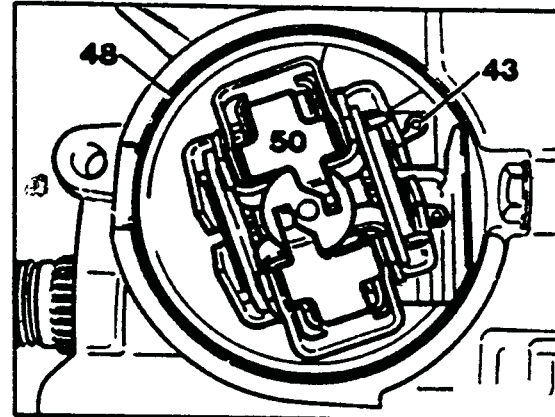

7-Remove allen screws and hex head bolts (71)

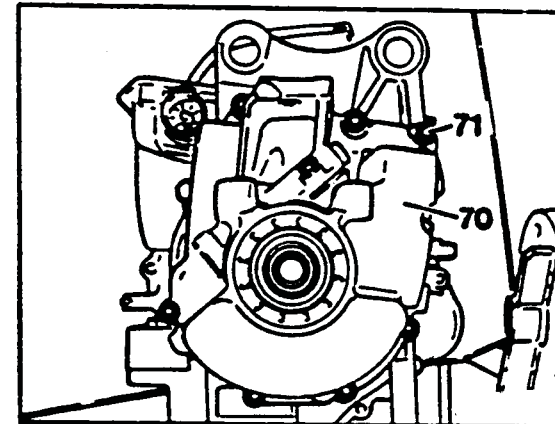

8-Loosen rear cover (70) by tapping lightly with a plastic hammer and remove.

9-Remove shims (163) and drive ring (164) from output shaft (86).

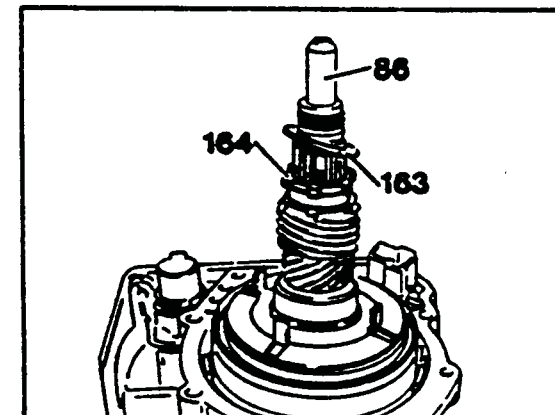



Technical Service Information

REMOVAL, INSTALLATION AND MEASUREMENT OF OVERDRIVE BRAKE "BS"

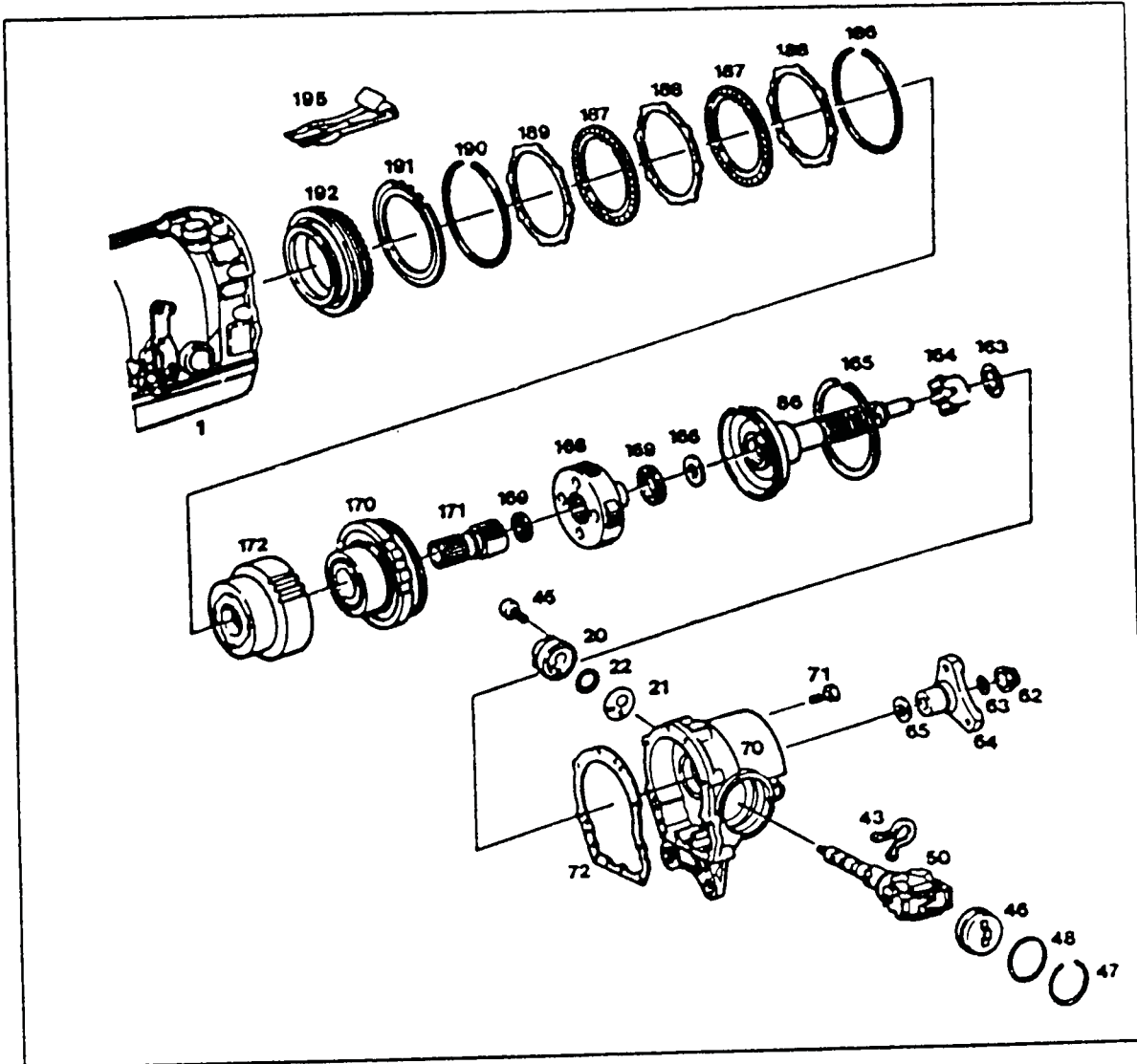

- | | |
|--|---|
| Bouble hex collar nut (62)..... | screw off, screw on 120 Nm. Secure with suitable punch. |
| Universal flange (64), washer (65)..... | remove, reinstall |
| Rear pump (20)..... | remove, install Temove O-ring (22) intermediate plate (21) allen screw (45) tighten to 8 Nm. |
| Retaining ring (47), cover (46)..... | remove, reinstall. |

Technical Service Information

10-Remove retaining ring (165 and output shaft (86).

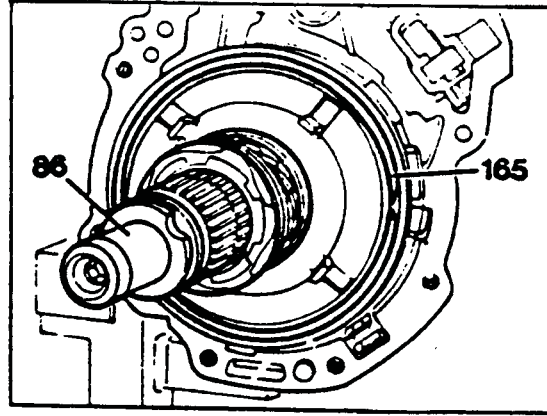

11-Remove shims (166) from intermediate shaft (167) and planetary gear carrier (168) from ring gear (170). Note position of 2 thrust bearings (169)

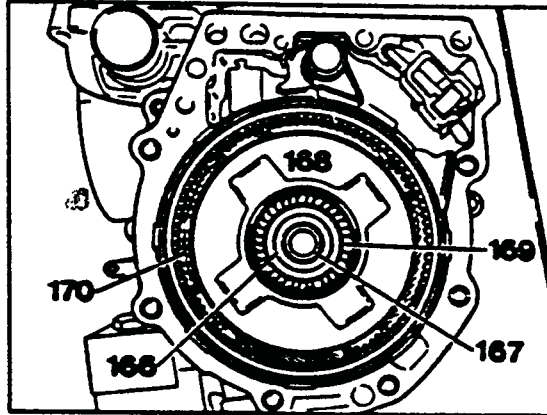

12-Remove sun gear (171) and ring gear (170).

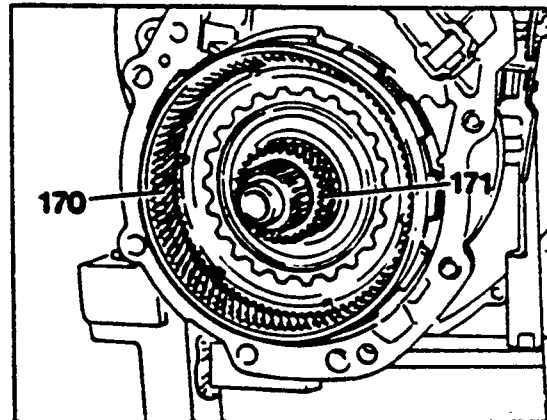

13-Remove plate carrier KS (172) with plate assembly.

14-Disassemble clutch KS.

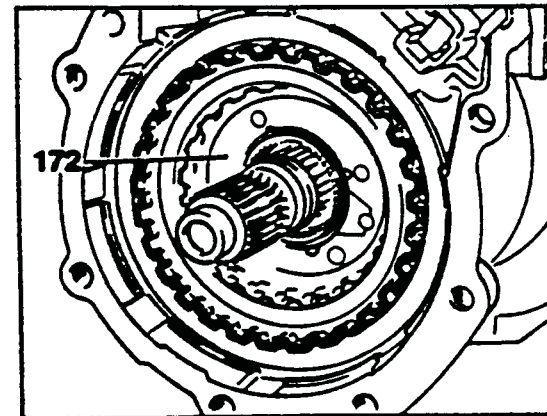



Technical Service Information

15-Remove retaining ring (186) and plate assembly BS from housing.

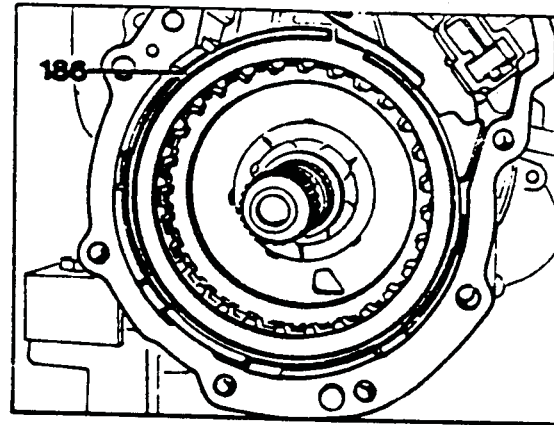

16-Pull off damping spring (195), remove retaining ring (190) and reed spring (191).

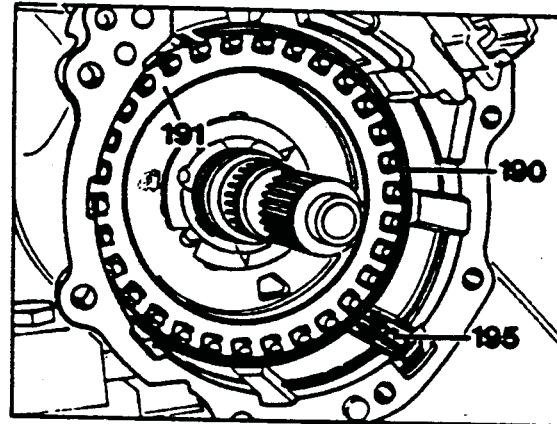

17-Pull piston BS (192) out of housing with 2 pairs of flat pliers. Remove teflon rings (196) and then thrust washer (173).

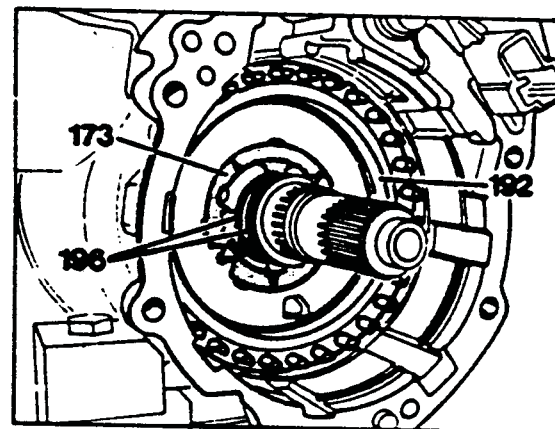



DISASSEMBLY, ASSEMBLY AND MEASUREMENT OF "KS" CLUTCH PACK

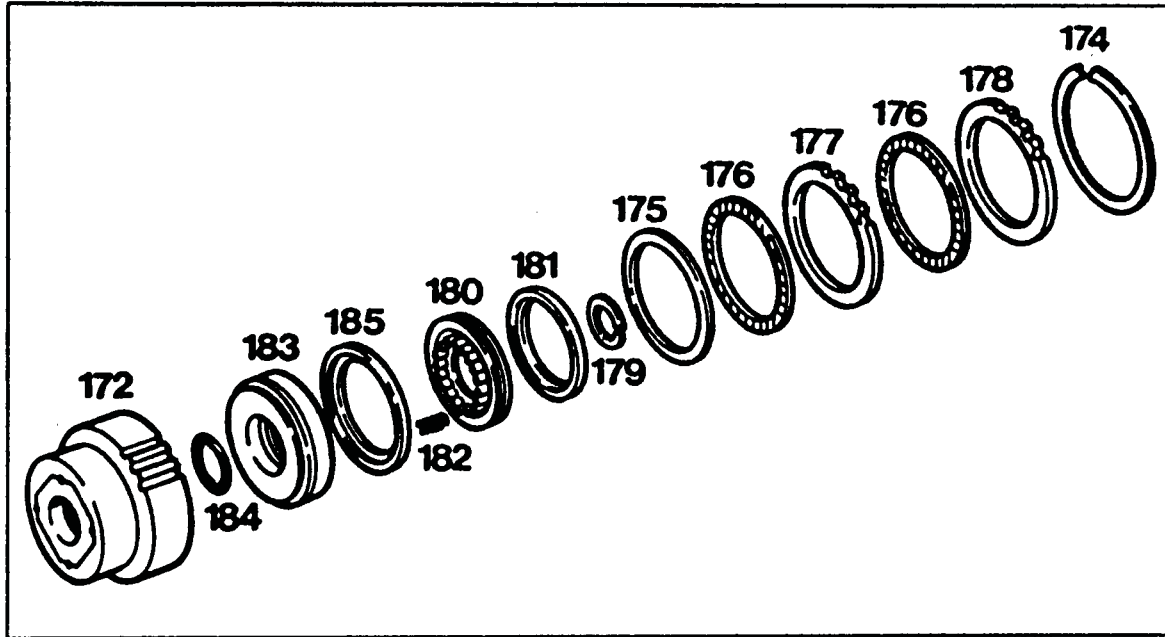

- | | |
|---|--|
| Retaining ring (174)..... | remove, install. Measure release clearance "S". |
| Outer plates (177)(178), inner plates (176) and plate spring..... | remove, install according to illustration. |
| Retaining ring (179) | remove, install for this purpose compress spring plate (180) with assembly tool until retaining ring is exposed. |
| Spring plate (180) and springs (182).... | remove, install, check number of springs in retainer. |
| Piston (183)..... | remove, install. |
| Lip seals (181)(189) ,sealing ring (184) | Replace lip seals. |



Technical Service Information

ASSEMBLY;

18-Lubricate both O-rings for piston BS (192) with transmission fluid and press piston into housing.

19-Insert thrust washer (173) so that tab to prevent rotation is set in housing and will not rotate.

20-Grease in support flange (79). Insert teflon rings (196) and press into groove until gap remains closed.

21-Insert reed spring (191), install retaining ring (190) and insert damping spring (195).

Note:

Do not mix up retaining rings, retaining ring (190) has an angled gap.

22-Assemble plates for brake BS in sequence shown in figure and insert individually.

23-Measure release clearance "S" with a feeler gauge and adjust to 0.5 to 1,1mm if required.

Note:

Retaining ring (186) is available in thicknesses of 2; 2.5; and 3 mm.

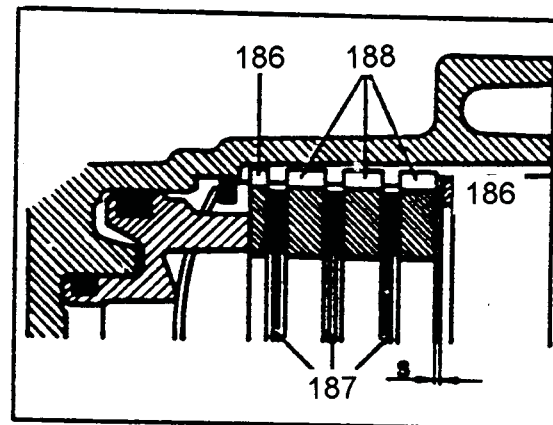
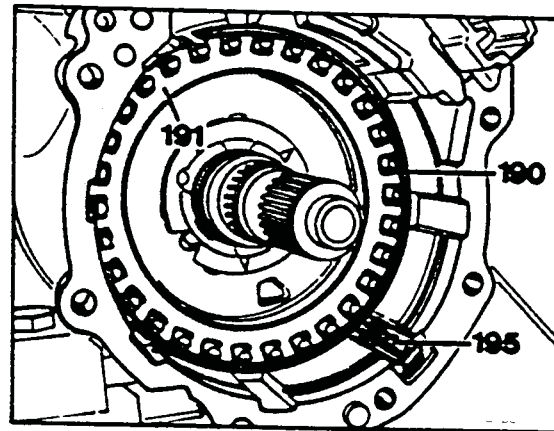
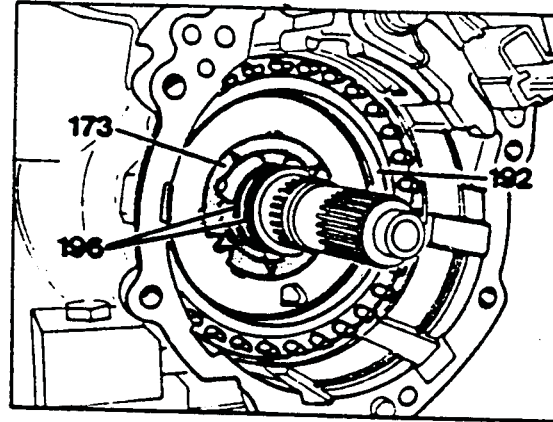

186 Retaining ring
 187 Inner plate
 188/189 Outer plate



Technical Service Information

24-Insert plate carrier KS (172) into plate BS>

Note:

The plate carrier is correctly installed when it can be lifted slightly and then drops back snugly against the thrust ring.

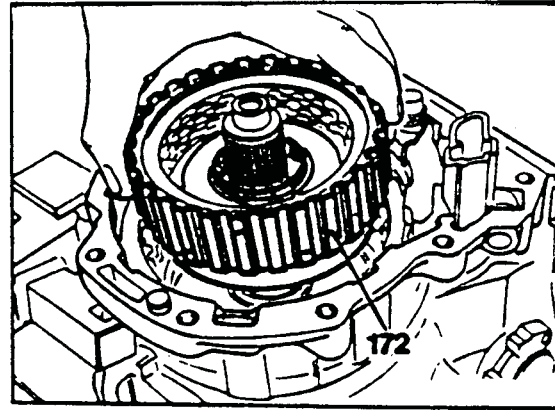

25-Carefully insert ring gear (170) into plates KS.

Note:

The ring gear is correctly installed when the upper edge of the park position pawl (arrow) is just slightly lower than the sealing surface on the housing.

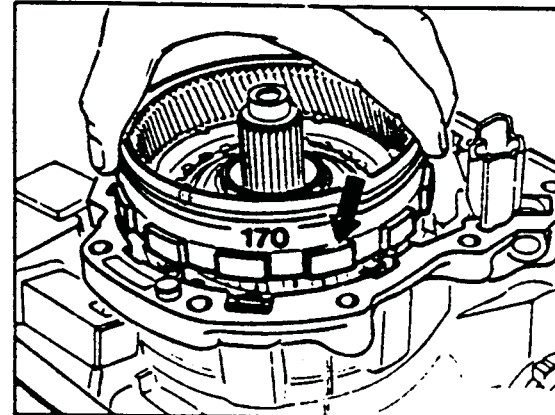

26-Insert sun gear (171)

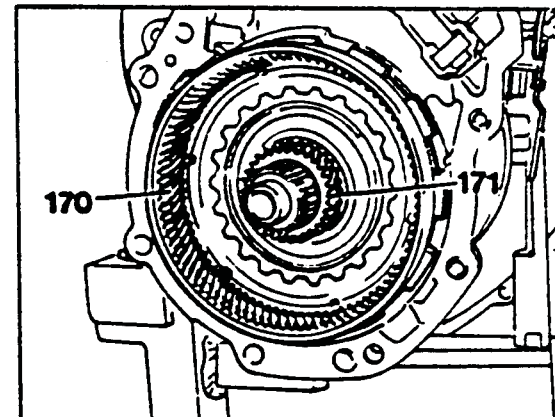

27-Insert planetary gear carrier (168) into ring gear (170). Assure that the inner thrust bearing (169) sticks on the planetary gear carrier.

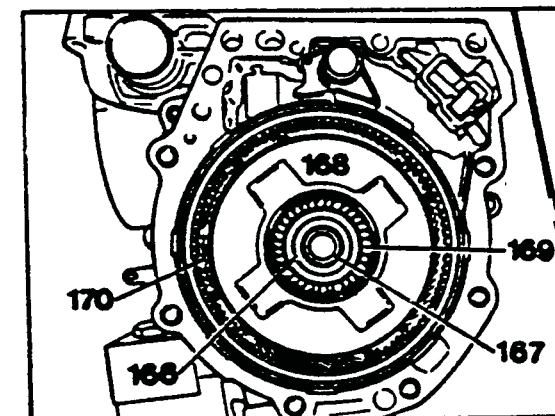

28-Position outer thrust bearing (169). Place shims (166) on intermediate shaft (167).



Technical Service Information

Measuring end play, output shaft-intermediate shaft
 Measure dimension "a"

29-Use depth gauge to measure from the bearing race surface of the output shaft (86) to the inner race of bearing (198).

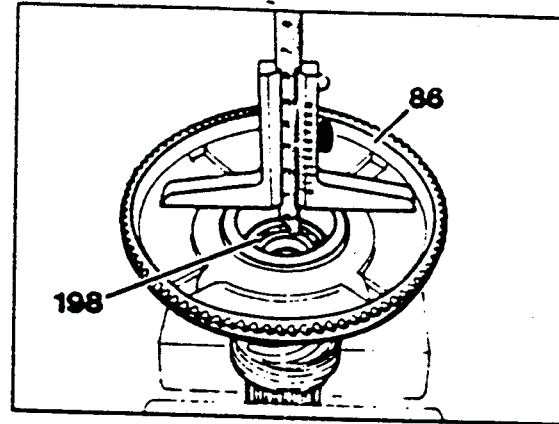

Measure dimension "b"

30-Use a depth gauge to measure from shims (166) to thrust bearing roller (169).

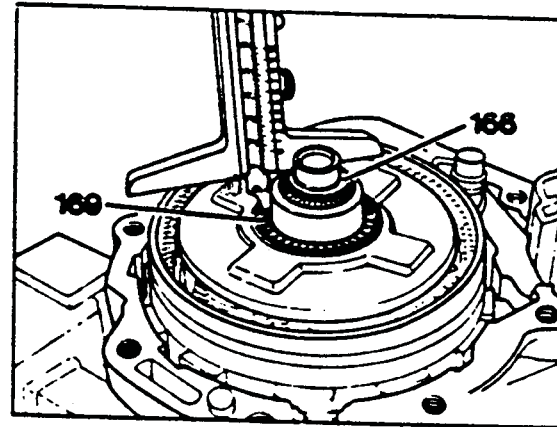

The end play "C" is equal to dimension "a" minus dimension "b". Set end play "C" to nominal value of 0.1mm. Adjust with shims (166) available in thicknesses of 0.1, 0.2 and 0.5mm.

31-Attach output shaft (86) and insert retaining ring (165).

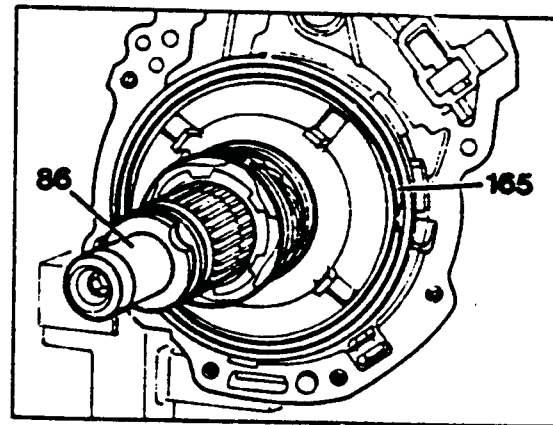



Technical Service Information

32-Position driving rings (164) and shims (163) on output shaft (86).

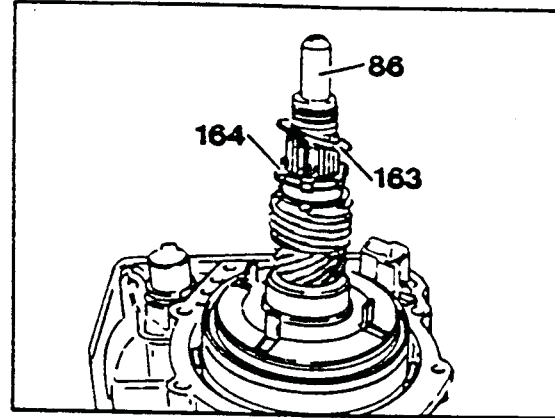

Measure end play, output shaft-rear cover.
Measure dimension "a"

33-Place measuring plate (028) (mercedes tool 129 589 06 23 00) on sealing surface of rear cover. Measure distance between measuring plate (028) and inner race of ball bearing (67) with depth gauge.

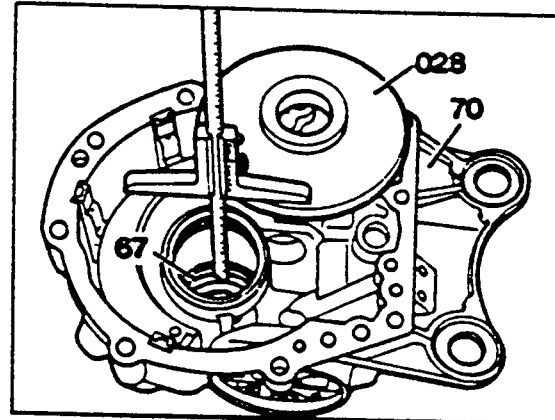

Measure dimension "b"

34-Attach measuring plate (028) (Mercedes tool 129 589 06 23 00) and universal flange, tighten collar nut (62) to 100 Nm. Engage parking pawl to hold while tightening, install gasket (72)

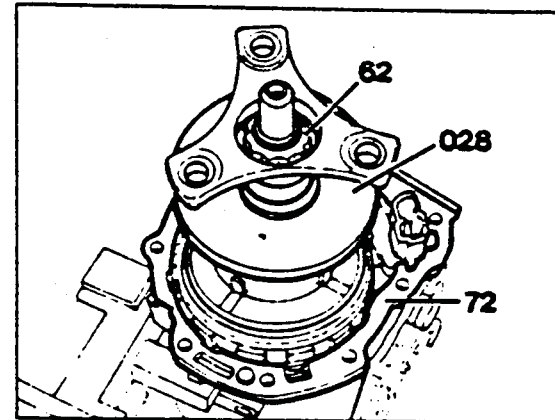

35-Use a depth gauge to measure the distance between measuring plate (028) and gasket (72).

The endplay "E" is equal to dimension "a" minus dimension "b".

36-If necessary adjust end play "E" to 0.4mm by inserting or removing shims.

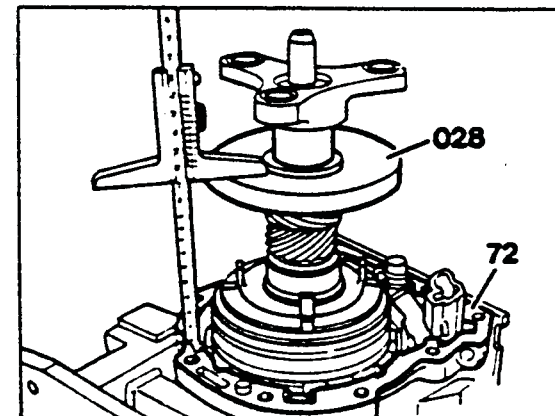



Technical Service Information

37-Attach rear cover (70). coat allen screws M8x55 and hex bolts M8x35 (71) with non-hardening sealant and tighten to 13 Nm.

Note:

The gaskets should be replaced however DO NOT coat with a sealant.

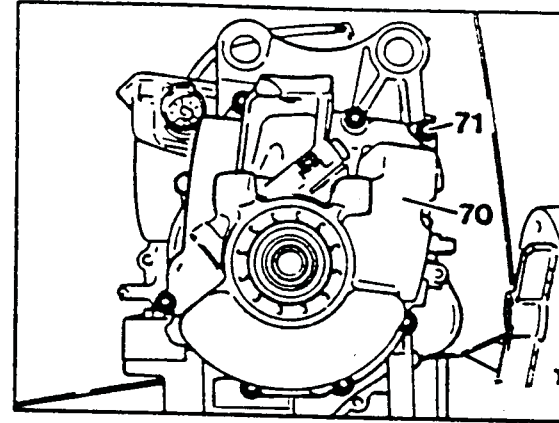

38- Insert O-ring (48)

39-Insert governor (50); turn bearing race so that tongue engages in groove in housing. Insert retaining ring (43) and assure that it catches in groove.

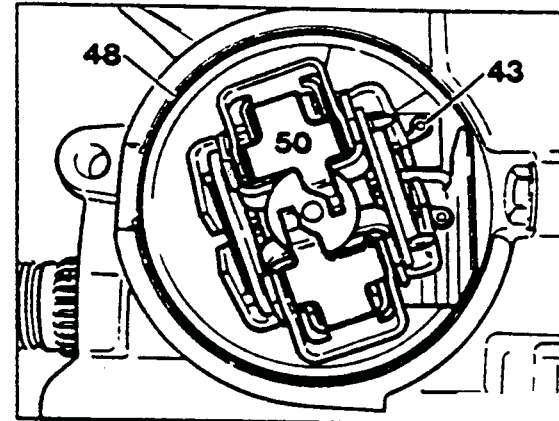

40-Insert cover (46) and install retaining ring (47) with aid of a screw driver. Then pull cover outward so that it contacts the retaining ring around the entire circumference.

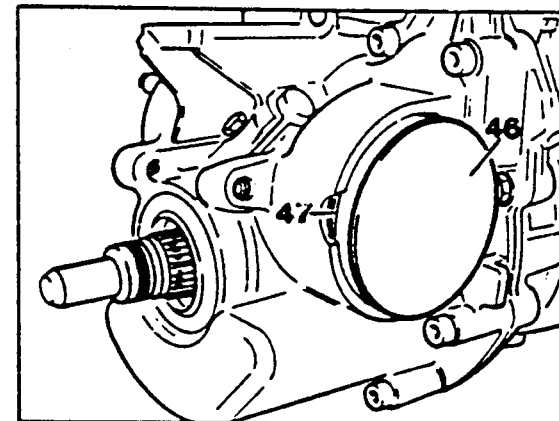

41-Insert intermediate plate (21) and O-ring (22).

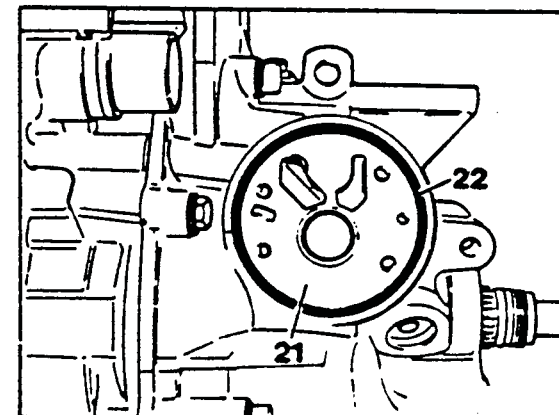

AUTOMATIC TRANSMISSION SERVICE GROUP



Technical Service Information

42-Attach rear pump (20), screw in allen screws (45) M6x30 and tighten to 8 Nm.

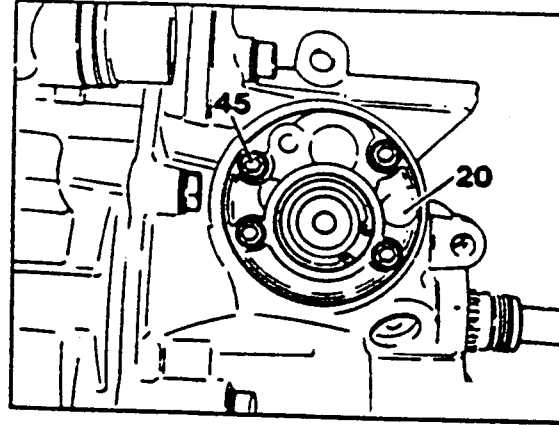

43-Insert washer (65).

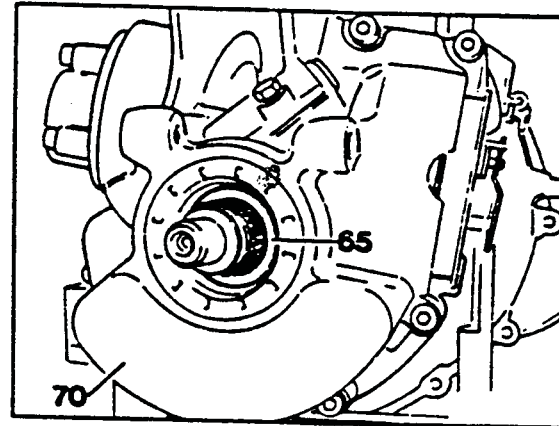

44-Insert O-ring (63) into universal flange (64).

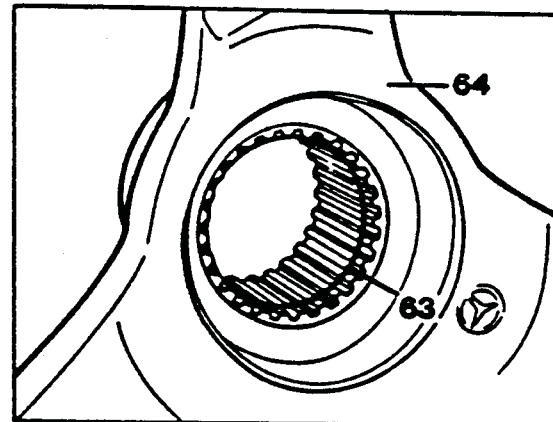

45-Attach universal flange (64), tighten double hex collar nut (62) to 120 Nm and secure by staking with suitable punch.

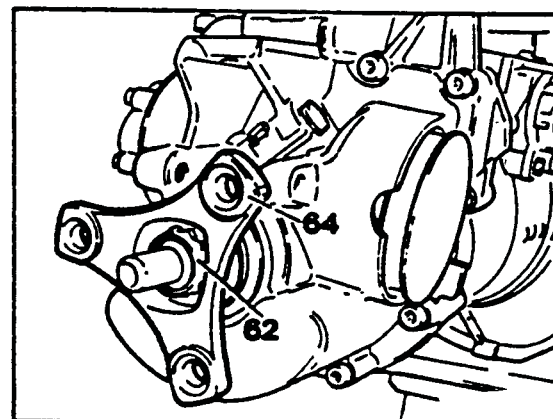



Technical Service Information

CLUTCH PLATE SEQUENCE

- 174 Retaining ring
- 175 Plate spring
- 176 Inner plate
- 177/178 outer plates

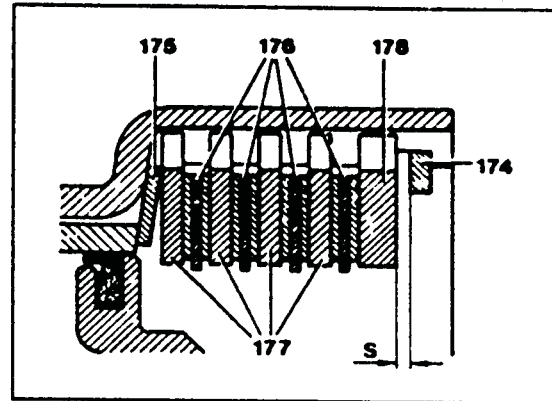

Teardown

1-Remove retaining ring (174) from plate carrier (172) and remove plate assembly.

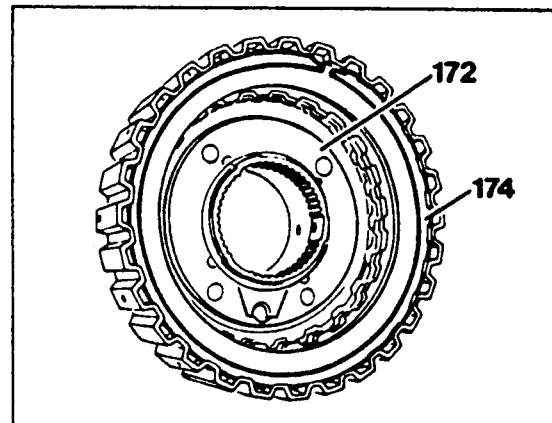

2-Position assembly device (020) (Mercedes tool 126 589 00 43 00) on plate spring (180) and compress spring until retaining ring (179) is exposed. Remove retaining ring.

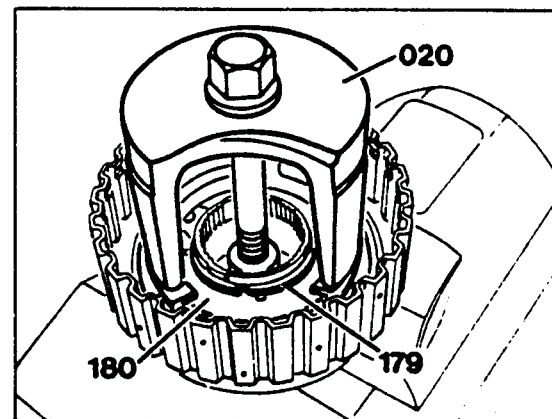



Technical Service Information

3-Remove spring plate (180) and pressure springs (182). Replace lip seal (181).

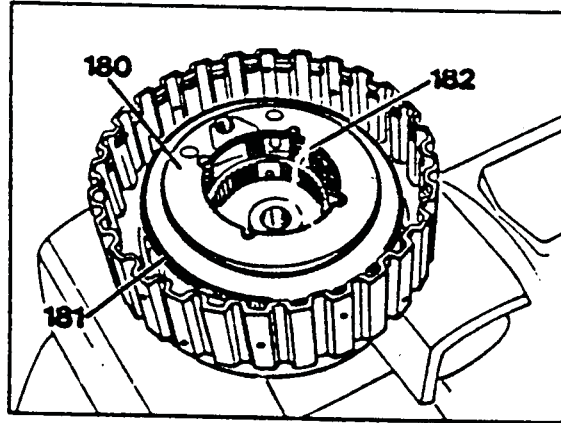

4-Pull piston (183) out of outer plate carrier (172)

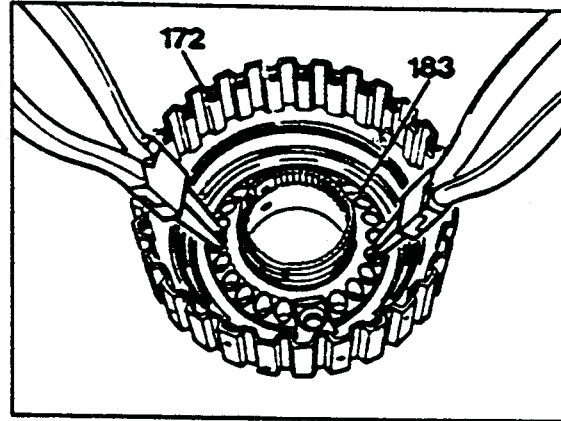

ASSEMBLY:

5-Position insertion sleeve (023) (Mercedes tool 129 589 00 14 00) in plate carrier (172). Replace lip seal (105 replace sealing ring (184). Lubricate with transmission fluid. Carefully insert piston (183) without cocking.

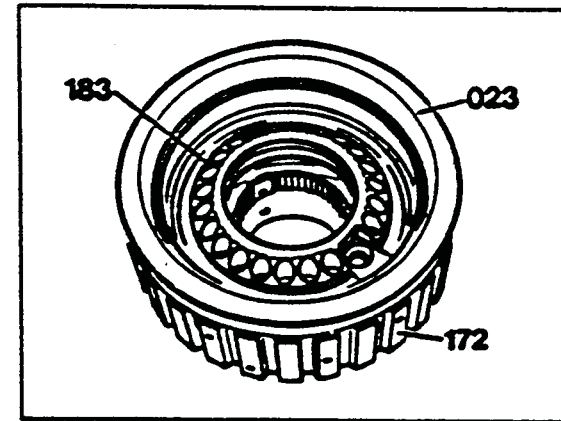

6-Remove insertion sleeve (023).

Note:

Assure that the lips of the seals (181) and (185) point downward after assembly.

- 172 Plate carrier KS
- 179 Retaining ring
- 180 Spring plate
- 181 Lip seal
- 183 Piston KS
- 184 Sealing ring
- 185 Lip seal

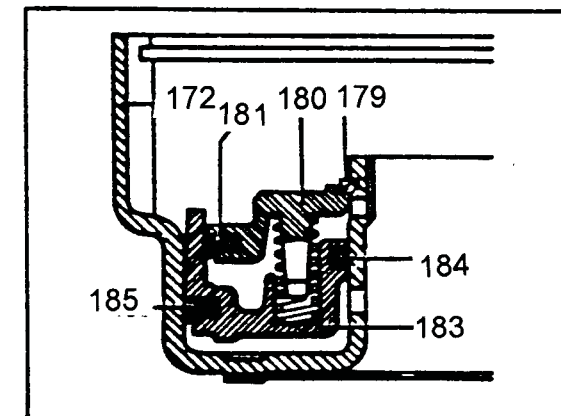



Technical Service Information

7-Position insertion sleeve (024) in plate carrier (172). Lubricate lip seal (181) with transmission fluid.

8-Insert all 18 or 19 return springs (182) into guide pins on piston (183).

9-Position spring plate (180)

10-Position retaining ring (179) on spring plate. Attach assembly device (020) and clamp. Insert retaining ring and assure that it seats properly.

11-Release assembly device and remove.

12-Position plates for clutch KS in sequence shown in figure and insert individually.

Note:

Soak new plates in transmission fluid for 1 hour before assembly

- 174 Retaing ring
- 175 Plate spring
- 176 Inner plates
- 177/178 Outer plates

13-Measure release clearance KS "S" with feeler gauge and adjust to 1.5-2.1mm with retaing ring (174)

Note:

Retaining ring (174) is available in thicknesses of 2; 2.5;3; 3.5

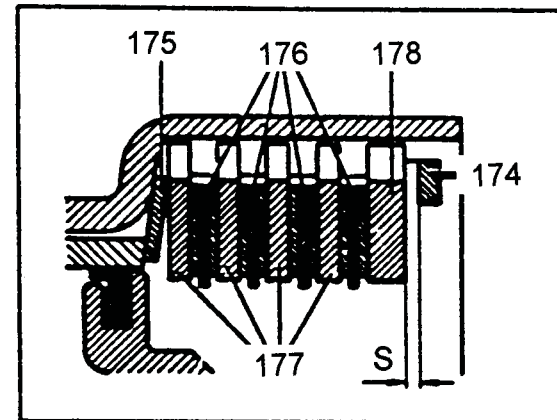
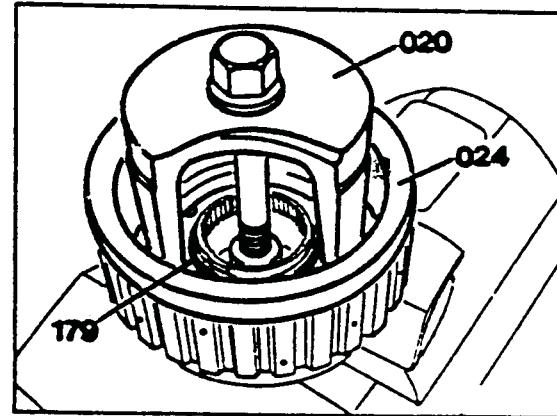
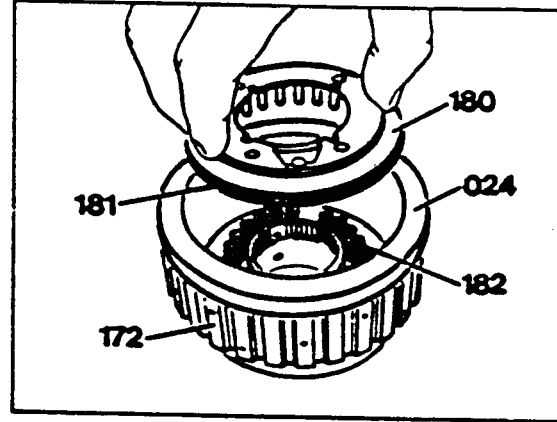



Technical Service Information

Disassembly-Assembly

1-Remove retaining ring (2) from ring gear(1) remove one-way clutch.

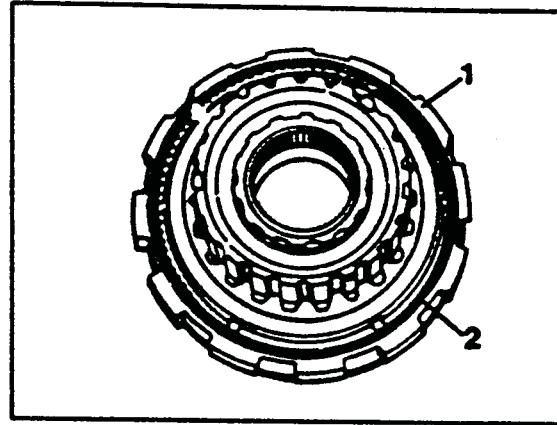

2-Remove retaining ring (4) and supporting disk (3)

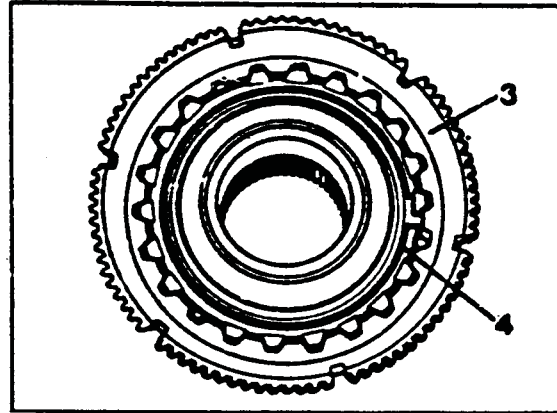

Installation note:

Assure that O-ring is positioned properly in groove.

3-Press one wayy clutch inner race (9) out of roller cage (6). Remove O-ring (5).

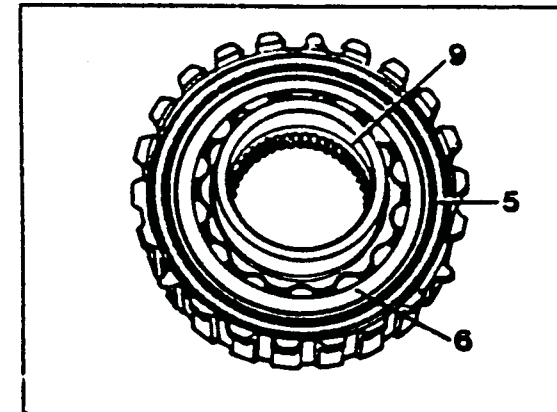

Installation note:

Insert one-way clutch inner race into roller cage (6). Hold one-way clutch inner race in place and turn roller cage counter-clockwise with self-made assembly plate (010) while pressing one-way clutch downward from outside.

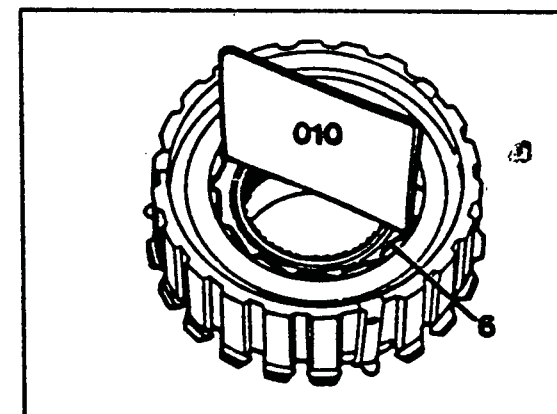



Technical Service Information

4-Remove roller cage (6) from one-way clutch outer race (10).

Caution:

The cylindrical rollers can pop out of the roller cage.

Installation note:

Insert roller cage (6) into one-way clutch outer race, then carefully press the individual pressure springs to the side and insert cylindrical rollers.

5-Check running surfaces of one-way clutch outer race (10) for chatter marks and damage.

6-Check cylindrical rollers (6a) and pressure springs (6b).

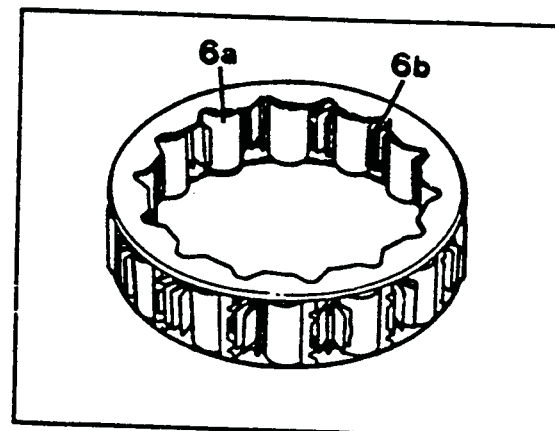
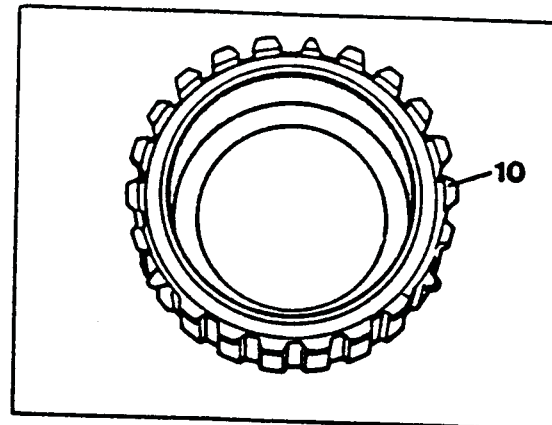
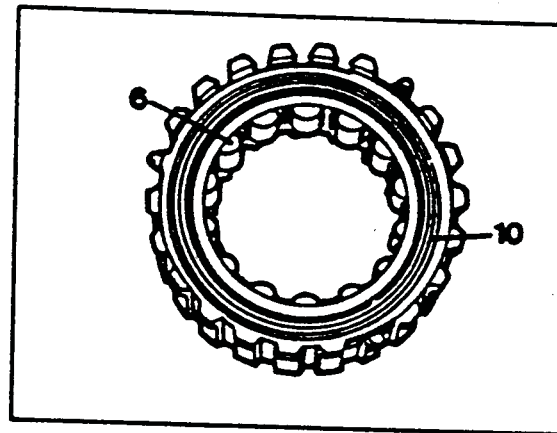



Technical Service Information

AUTOMATIC TRANSMISSION SYSTEMS

MODEL YEAR 1990

	SHIFT LOCK	OVERLOAD PROTECTION	DELAYED SHIFTING	SHIFT TO 5TH GEAR
190E 2.6 M-103	YES	NO	YES	NO
260E M103	YES	NO	YES	NO
300E M-103	YES	NO	YES	NO
300TE M-103	YES	NO	YES	NO
300CE M-104	YES	YES	YES	NO
300SE/SEL M-103	YES	NO	YES	NO
300SL M-104	YES	YES	YES	YES
500SL M-119	YES	YES	YES	NO
450SEL M-116	YES	NO	NO	NO
560SEL M-117	YES	NO	NO	NO
DIESELS OM-602&603	YES	NO	NO	NO

NOTE: THE SHIFT LOCK WILL BE INSTALLED ON ALL MODELS FOR 1990.
: ADDITIONAL TECHNICAL INFORMATION IS AVAILABLE IN GROUP 27
OF MODEL 1990 AND 129 INTRODUCTION BOOKS



Technical Service Information

SHIFT LOCK SYSTEMS 1990 MODELS

There are two separate Shift Lock Systems on all 1990 models. One operated by the ignition switch and the other by the brake pedal.

PURPOSE:

IGNITION SHIFT LOCK.

The ignition shift lock assures that the ignition switch is ON before the selector lever can be moved from park.

It also assures that the shift selector lever is in PARK before the ignition key is removed.

BRAKE SHIFT LOCK.

The brake shift lock assures that the drivers foot is on the BRAKE pedal before selecting a drive gear.

IGNITION SHIFT LOCK OPERATION:

A cable connects a slide in the ignition switch housing to a pawl on the transmission shift housing.

When the ignition switch is turned ON, a cam moves the slide and cable toward the transmission. It is this cable movement that lifts the pawl away from a cam on the selector lever shaft, and allows the selector to move into gear.

Once the shift lever is placed in a drive gear, the cam and pawl on the shift housing will hold the cable in an extended position. The slide attached to the cable cannot return to its rest position and therefore the ignition key cannot be removed.

To remove the key from the ignition switch, place the shift lever in PARK. Park position will allow the pawl and cable to retract, and the slide to return to its rest position releasing the ignition key.

BRAKE SHIFT LOCK OPERATION:

The brake shift lock also works via a cable. A notch in a cam attached to the shift lever shaft and a pawl holds the shift lever in PARK until the BRAKE pedal is depressed. Depressing the BRAKE pedal moves the cable and pawl away from the cam, allowing the shift lever to move into a drive gear.

ADJUSTMENTS

Refer to preliminary procedures in the R-129 Introduction Book. The complete adjustment will be on Service Micro Fiche.



Technical Service Information

IGNITION SHIFT LOCK

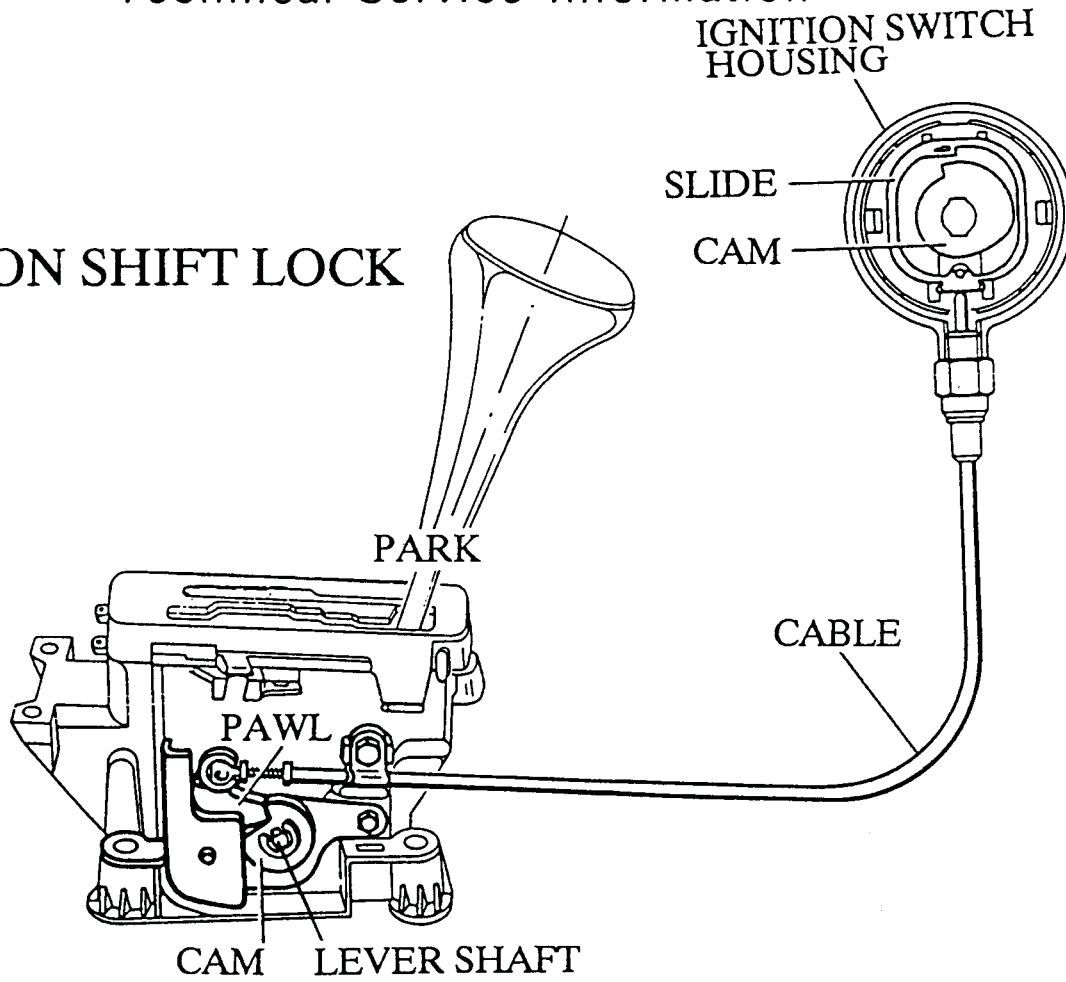

BRAKE SHIFT LOCK

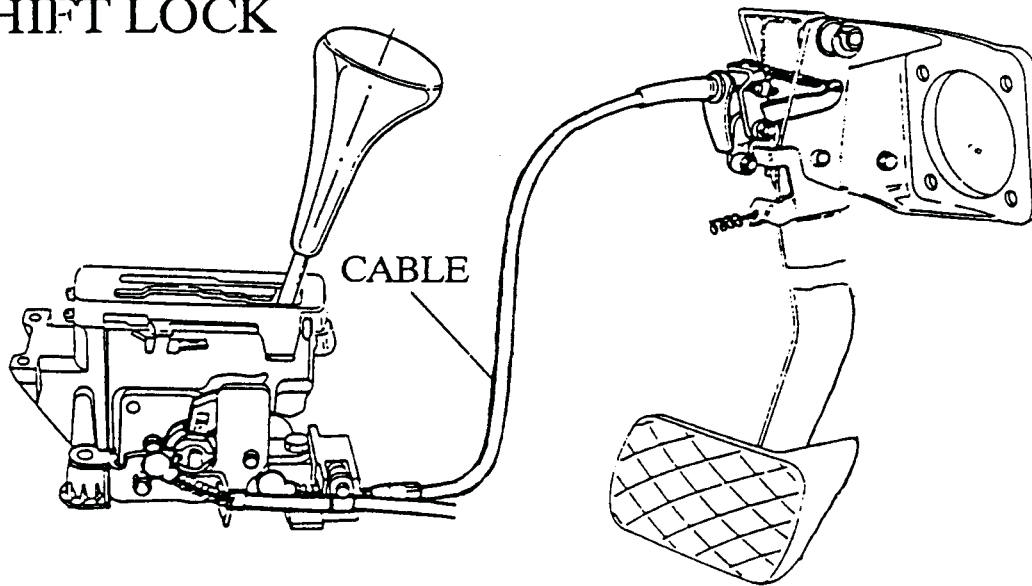



Technical Service Information

DELAYED 2-3 SHIFTING

BELOW 40°C COOLANT TEMPERATURE

ALL 1990 MODELS EQUIPPED WITH M-103, M-104, AND M119 ENGINES

FOUR AND FIVE SPEED TRANSMISSIONS.

PURPOSE

To warm up the catalyst faster.
 Note: these vehicles do not have pre-catalyst.

OPERATION

- a. The 2-3 upshift will be delayed at light throttle when the engine coolant temperature is below 40°C.
- b. Switchover Y3/2 is electrically opened providing reduced governor pressure.

HYDRAULIC OPERATION

The external switchover valve Y3/2 is connected to the governor circuit. When electrically activated, this switchover valve opens and bleeds off some of the governor oil, which reduces governor pressure and delays the 2-3 upshift.

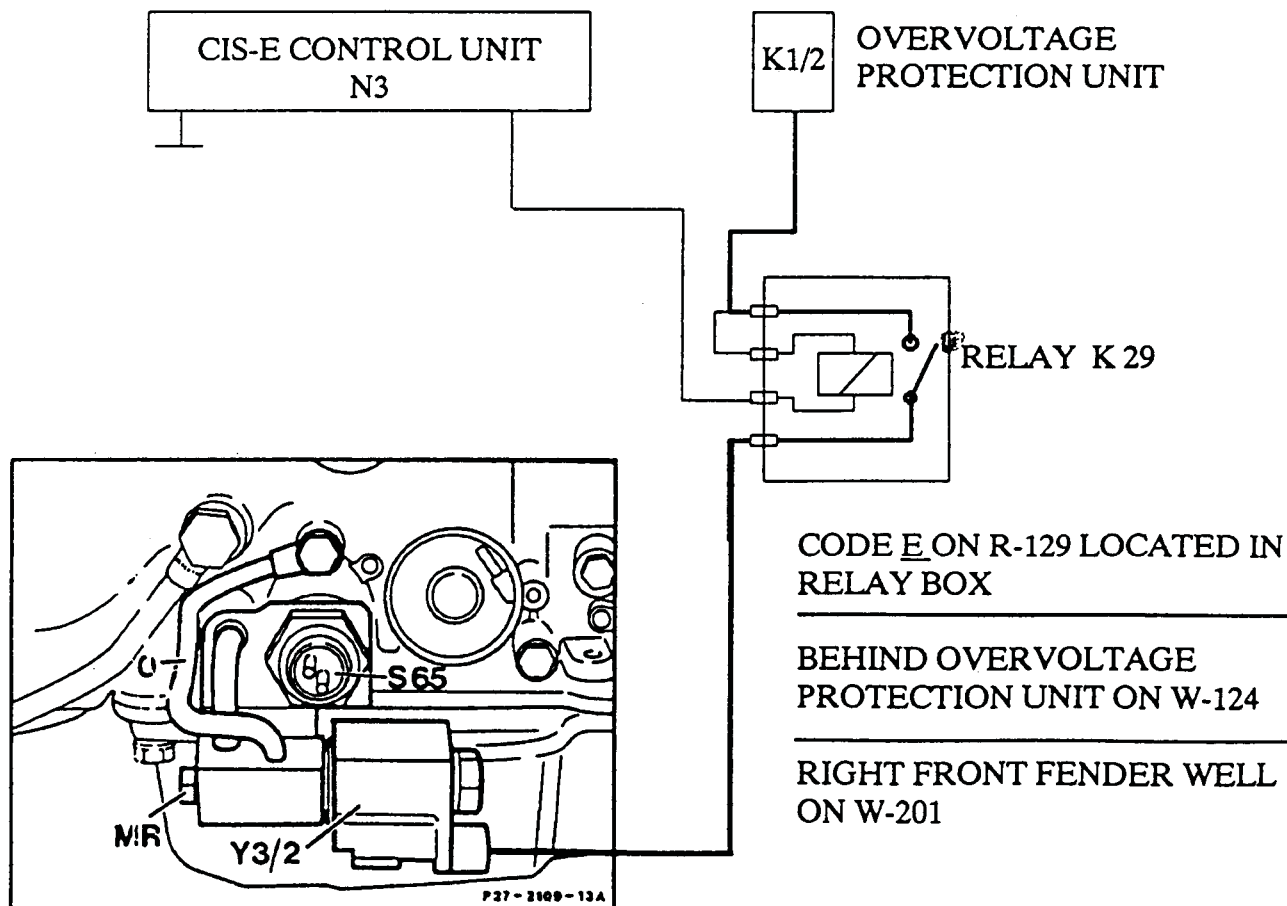

AUTOMATIC TRANSMISSION SERVICE GROUP



Technical Service Information

AUTOMATIC TRANSMISSION OVERLOAD PROTECTION

722.353 4 SPEED M-119 ENGINE

722.500 5 SPEED M-104 ENGINE

PURPOSE

- a. Protect transmission from thermal overload.
- b. Improves shift quality of 2-3 upshifts at full throttle.

OPERATION

RETARDS IGNITION TIMING FOR 400 MILLISECONDS:

- a. 1-2 and 2-3 upshift above 4000 R.P.M..
- b. 3-2 down shift at full throttle.
- c. The EZL unit receives a signal from S65.
- d. Switch S65 is controlled by the reaction valve for band 1.

BACKUP OPERATION

If the EZL unit does not receive a signal from switch S65, the system goes into backup operation. The timing will be retarded for a shorter duration according to engine R.P.M. changes.

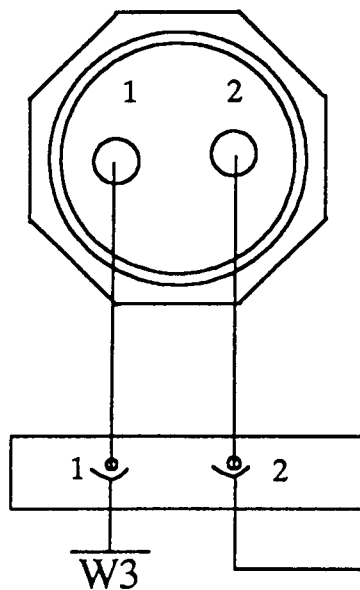

S65 IS LOCATED ON THE GEAR BOX TO THE FRONT OF THE MODULATOR

S65 IS CONTROLLED BY
B 1 REACTION VALVE

X22/2 LOCATED UNDER THE DASH TO THE LEFT OF THE STEERING COLUMN ON R-129

N13 (B.3) EZL/AKR UNIT

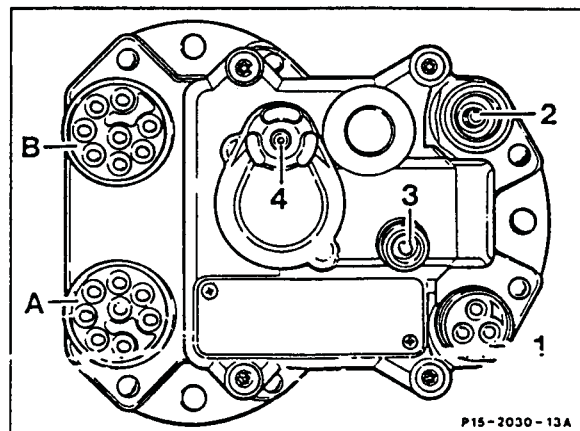

AUTOMATIC TRANSMISSION SERVICE GROUP



Technical Service Information SHIFT TO 5TH GEAR

Shifting into 5th gear is controlled by the HGS unit, switch over valve Y3/1y2, and a hydraulic circuit in the valve body. For a complete description refer to the R129 Introduction Book.

INPUTS

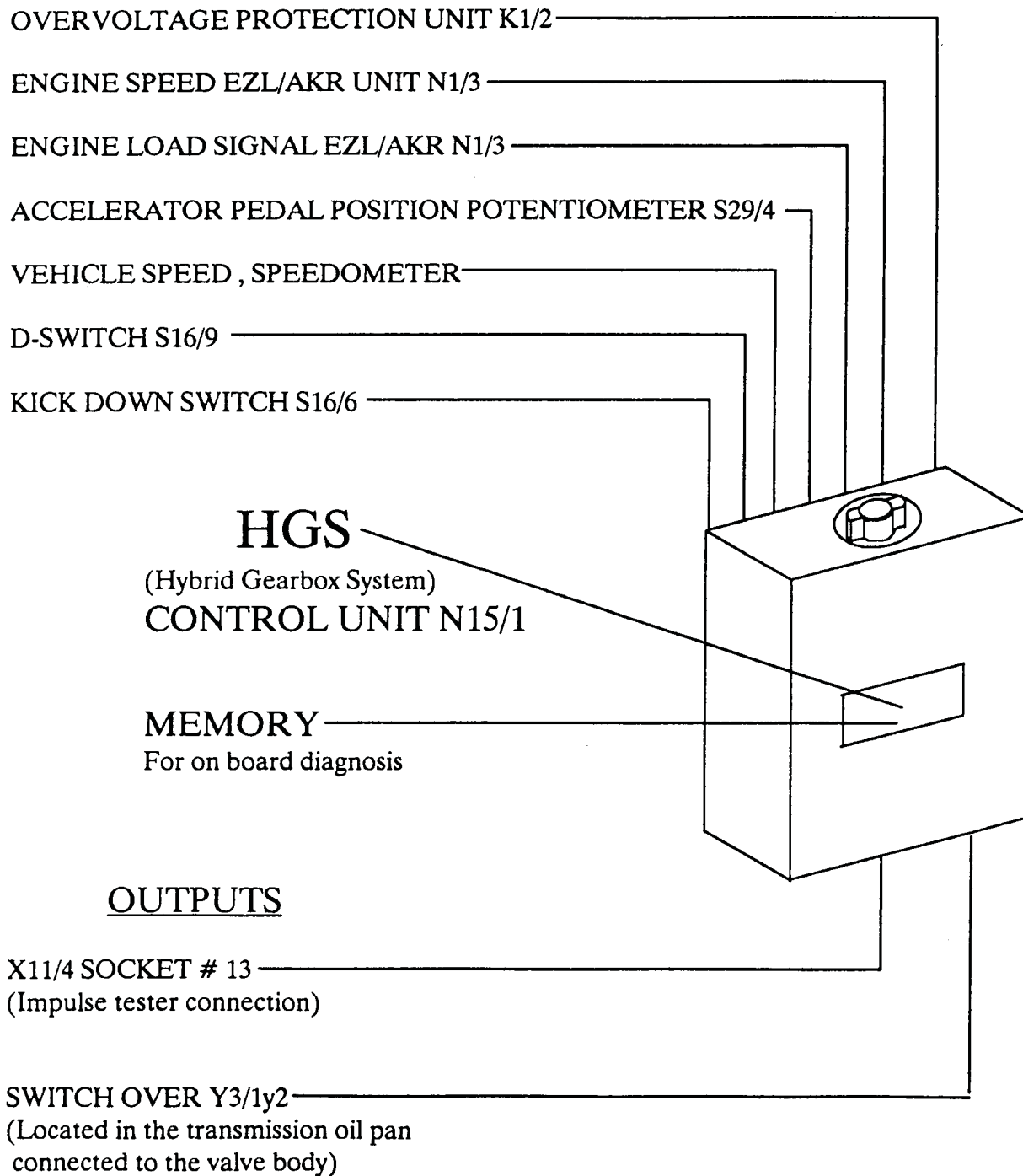



Technical Service Information

722.5
FIVE SPEED
AUTOMATIC TRANSMISSION

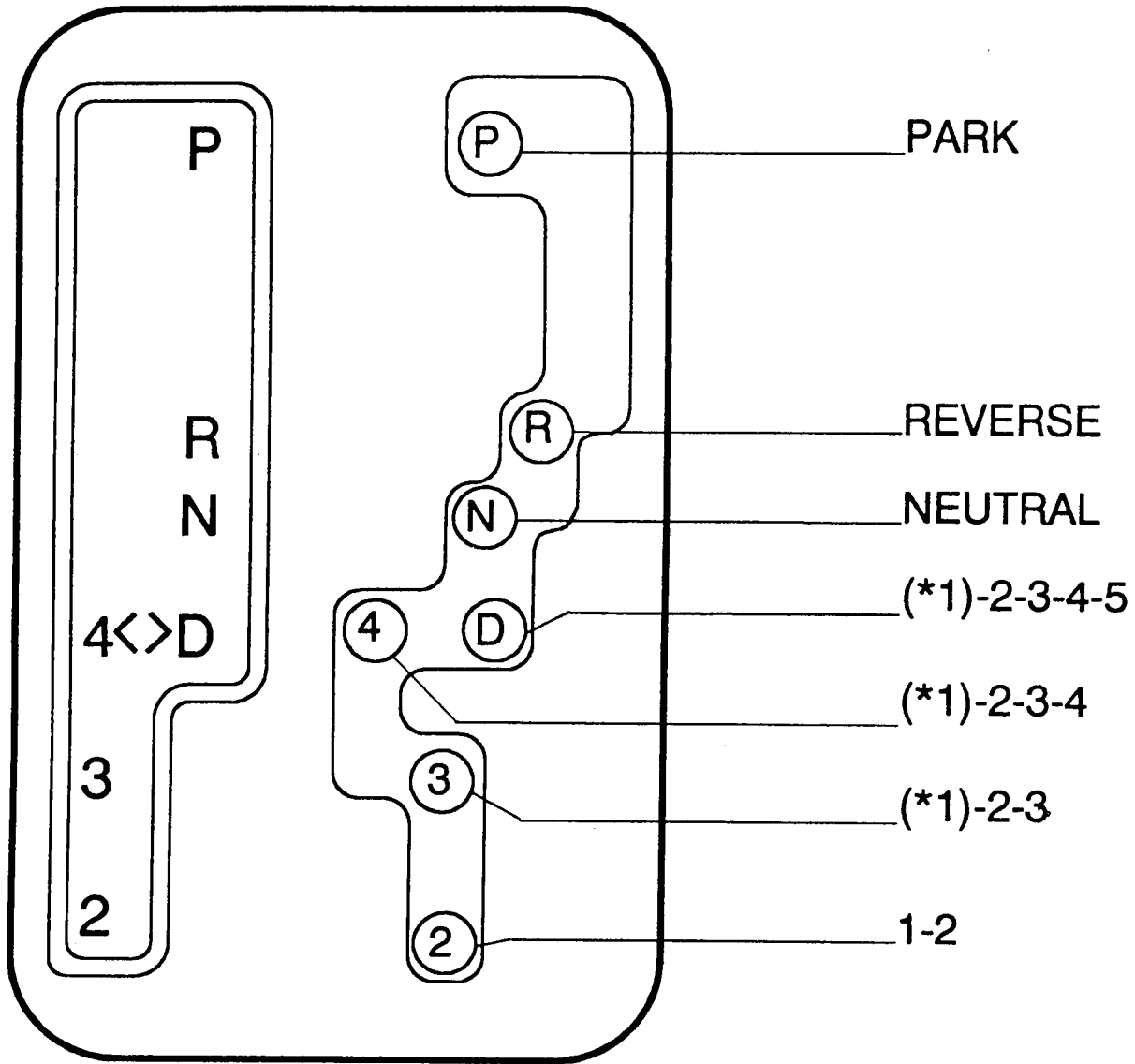

(1*) OCCURS AT FULL THROTTLE OR KICKDOWN



Technical Service Information

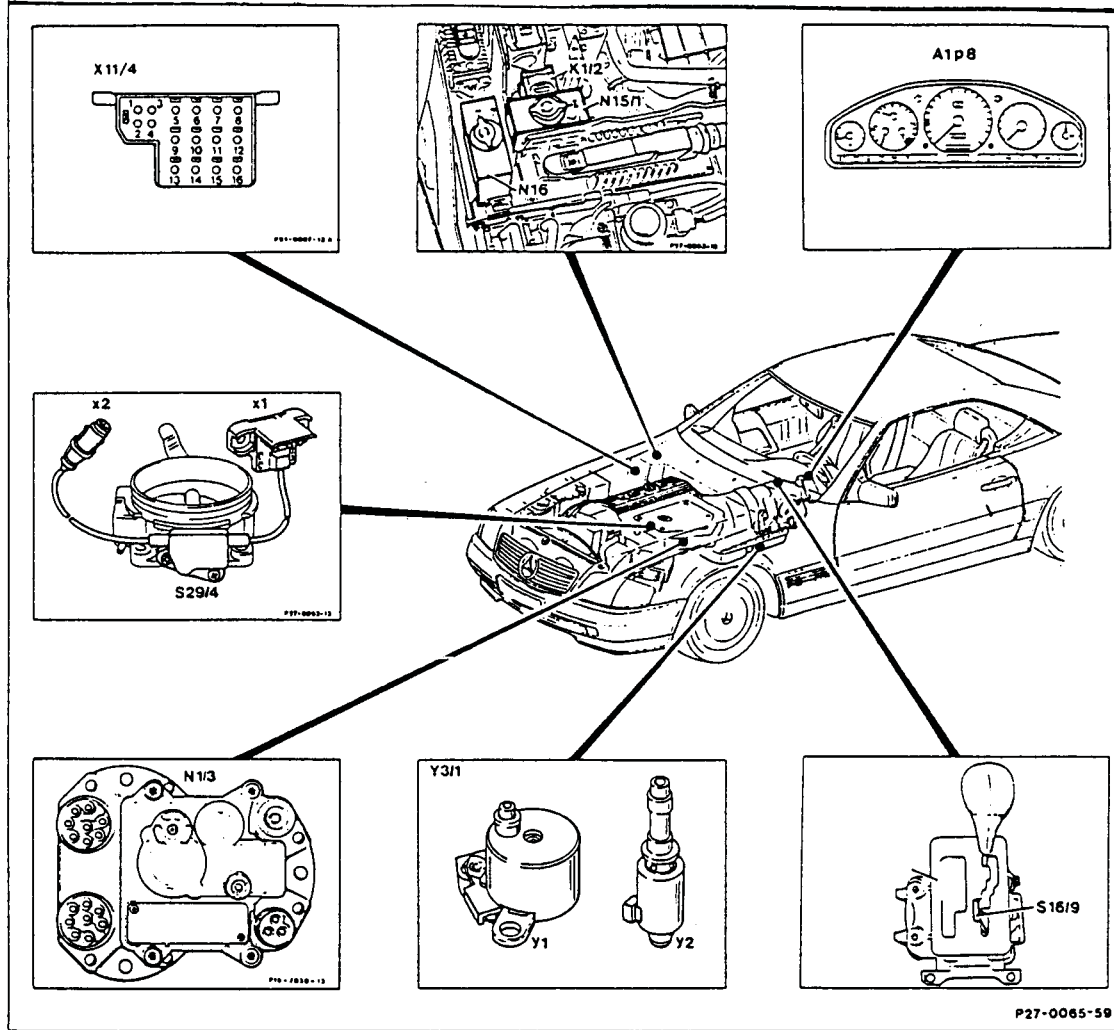

- | | | | |
|-------|---|--------|--|
| A1p8 | Electronic speedometer | S29/4 | Accelerator pedal <i>POT.</i> |
| K1/2 | Overvoltage protection relay, 87 E/87 L/30a (9-pole) | X11/4 | Test connection for diagnosis (impulse readout, 16-pole) |
| N1/3 | Electronic ignition control unit (EZL)/anti-knock control (AKR) | Y3/1 | Valve block (5-speed automatic transmission) |
| N15/1 | 5-speed automatic transmission control unit | Y3/1y1 | Kickdown solenoid valve |
| N16 | Engine systems control unit (MAS) | Y3/1y2 | Control valve |
| S16/9 | "D" contact switch | | |

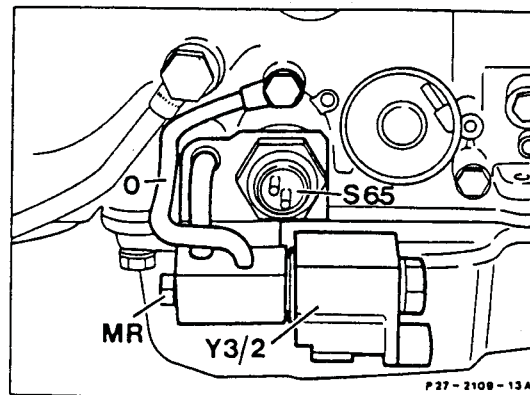

- | | |
|------|---|
| 0 | Oil pan drain |
| MR | Control pressure measurement connection |
| Y3/2 | Adjustable shift point solenoid valve |

AUTOMATIC TRANSMISSION SERVICE GROUP



Technical Service Information

Clutch and Band Application Charts

Three Speed Transmission								
LEVER POSITION		Gear	B3	B1	B2	K1	K2	F1
D	S	1st		X	X			
		2nd			X	X		
		3rd					X	X
L		1st		X	X			
R		Rev	X					X

NOTE: Three speed transmissions always start in first gear.

Four Speed Transmission										
LEVER POSITION				Gear	B1	K1	B3	K2	B2	F1
D	4	3	2	1st					X	X
				2nd	X				X	
			3rd		X			X		
			4th		X		X			
			1st				* X	X	X	
R				Rev			X	* X		X

NOTE: 722.1 & 2 uses a band for B3. while 722.3 & 4 use a Multiple Disc Brake.

* Clutch 2 is applied to provide engine braking.

For starting gear, refer to standing Starting/Starting gear chart.

Five Speed Transmission													
LEVER POSITION				Gear	B1	K1	B3	F1	K2	B2	BS	KS	F2
D	4	3	2	1st				X		X		X	X
				2nd	X					X		X	X
			3rd		X				X		X	X	
			4th		X			X			X	X	
			5th		X			X		X		X	
R				Rev			X	X	X		X		

NOTE: The five speed transmission starts in first gear at full throttle and kick down.

LEGEND : X = Activated or locked.
 K1 - Clutch 1
 F1 or F2 - One Way Roller Clutch
 KS - Clutch KS
 B1 - Band 1
 B3 - Band 3 or multiple Disk Brake
 BS - Multiple Disc Brake



OPERATION OF MECHANICAL ELEMENTS

The powerflow is identical with the four-speed transmission. This is achieved by the sprag holding (F2) and the application of the KS clutch in the rear planetary. In many ways its operation is the same as over-run clutches in other automatics both imports and domestic units.

The KS operates like an over-run clutch pack. When the unit will shift into overdrive this clutch pack will release. When this unit shifts into 5th speed (overdrive, the KS clutch releases the F2 sprag free-wheels and the BS clutch in the rear of the unit puts the rear planetary into overdriven mode.

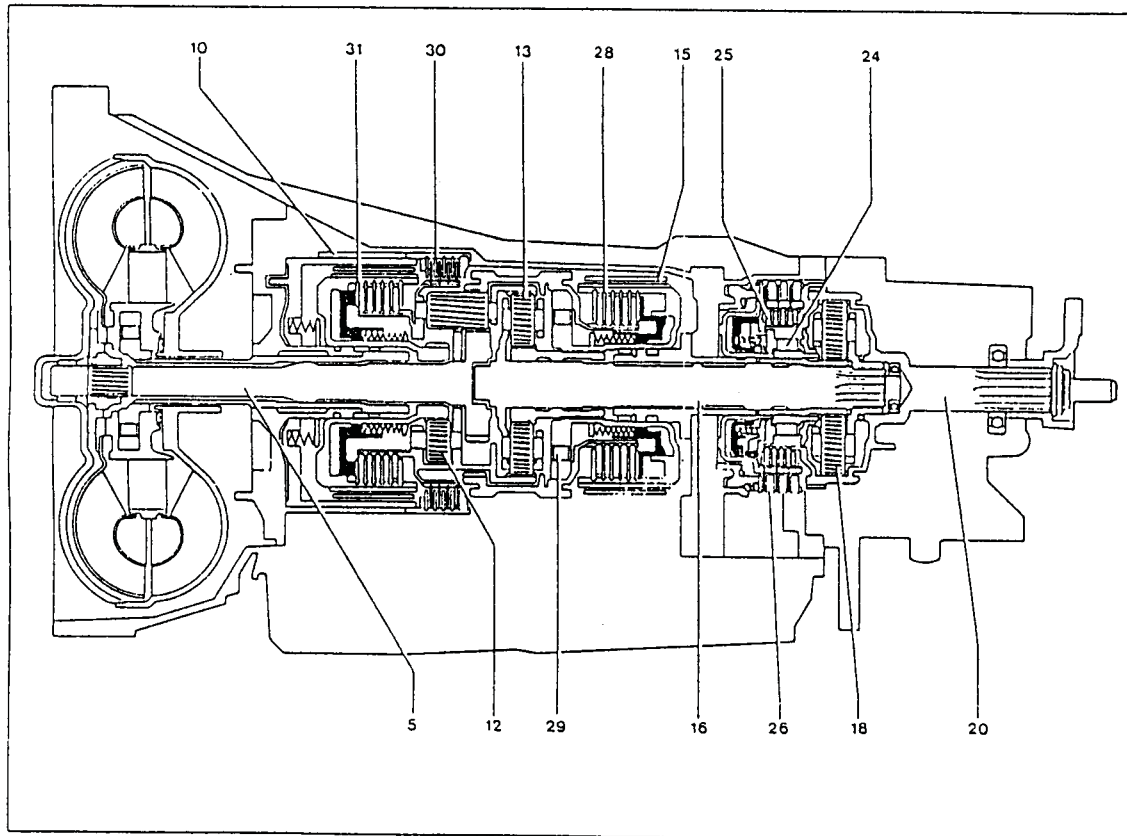

- | | | | |
|----|------------------------------|----|----------------------|
| 5 | Input shaft | 24 | Sprag clutch F2 |
| 10 | Brand band B1 | 25 | Clutch KS |
| 12 | Ravigneux planetary gear set | 26 | Brake BS |
| 13 | Middle planetary gear set | 28 | Clutch K2 |
| 15 | Brake band B2 | 29 | Sprag Clutch F1 |
| 16 | Intermediate shaft | 30 | Multi-disc clutch B3 |
| 18 | Rear Planetary gear | 31 | Clutch K1 |
| 20 | Output shaft | | |



Technical Service Information

Test Data

Vehicle Model & (trans. type)	Accelerator Pedal Position	Upshift Range (mph) ¹⁾				Downshift Range (mph) ¹⁾				Working Pressure	Governor Pressure		Modulator Pressure
		1→2	2→3 2)	3→4	4→5 3)	5→4 3)	4→3	3→2	2→1		18 mph	56 mph	
124.026 (722.409)	Light Throttle	-	14 - 21	20 - 28	-	-	20 - 13	8 - 11	-	-	-	-	-
	Full Throttle	15 - 24	46 - 60	79 - 94	-	-	54 - 67	21 - 29	9 - 14	10.9 ± 1.0 bar	0.9 bar	2.4 bar	3.3 bar
	Kickdown	24 - 31	52 - 62	86 - 97	-	-	75 - 92	42 - 58	16 - 22	-	-	-	-
124.128 (722.418)	Light Throttle	10 - 13	13 - 19	20 - 26	-	-	14 - 19	10 - 13	7 - 9	15.6 ± 1.0 bar	0.9 bar	2.5 bar	3.25 bar
	Full Throttle	21 - 27	41 - 51	76 - 83	-	-	50 - 56	23 - 28	12 - 16	-	-	-	-
	Kickdown	26 - 29	50 - 52	81 - 83	-	-	71 - 79	38 - 46	22 - 26	-	-	-	-
129.061 (722.500)	Light Throttle	-	13 - 20	23 - 30	45 - 52	26 - 33	15 - 23	9 - 13	-	12.7 ± 1.0 bar	0.9 bar	2.3 bar	3.8 bar
	Full Throttle	16 - 25	46 - 58	65 - 88	129 - 143	110 - 123	50 - 60	22 - 30	11 -	-	-	-	-
	Kickdown	35 - 37	60 - 60	86 - 96	129 - 143	122 - 136	77 - 92	46 - 58	22 - 22	-	-	-	-
201.029 (722.409)	Light Throttle	-	13 - 19	20 - 26	-	-	13 - 19	8 - 11	-	10.9 ± 1.0 bar	0.9 bar	2.4 bar	3.3 bar
	Full Throttle	14 - 22	43 - 56	74 - 88	-	-	51 - 63	21 - 27	8 - 13	-	-	-	-
	Kickdown	22 - 29	50 - 58	81 - 91	-	-	70 - 86	40 - 54	16 - 20	-	-	-	-

1) The speeds given in the chart above are given as reference, and are not intended for use as guidelines in an actual road test. MBNA does not require nor recommend testing, on public roads, which exceeds posted state speed limits. Such testing should be conducted on a test track or dynamometer.

2) Delayed 2→3 upshift range at light throttle with low engine coolant temperatures occurs at:
(models 124.026, 129.061, 201.029) 26 - 31

3) Model 129.061 only.

Test Results (to be filled in by Technician)

Vehicle Model & (trans. type)	Accelerator Pedal Position	Upshift Range (mph)				Downshift Range (mph)				Working Pressure	Governor Pressure		Modulator Pressure
		1→2	2→3	3→4	4→5	5→4	3→4	3→2	2→1		18 mph	56 mph	
	Light Throttle												
	Full Throttle												
	Kickdown												